

User manual and  
Spare Parts List

GARUDAN®

**GF-138 Serie L100**

**GF-238 Serie L100**



ANITA B, s.r.o.

Hliníky 2068

680 01 Boskovice

Czech Republic

tel: +420 516454774, 516453496

fax: +420 516452751

e-mail: [info@anita.cz](mailto:info@anita.cz)

*Caution:*

*In case of sage the machine with HVP-70 motor, change the output JP3  
On motor's main board from 5V to 12V.*

[www.garudan.cz](http://www.garudan.cz)

## PRECAUTIONS BEFORE STARTING OPERATION

### 1. Safety precautions

- 1) When turning the power on, keep your hands and fingers away from the area around/under the needle and the area around the pulley.
- 2) Power must be turned off when the machine is not used, or when the operator leaves his/her seat.
- 3) The power must be turned off before tilting the machine head, installing or removing the "V" belt, adjusting the machine, or when replacing.
- 4) Avoid placing fingers, hairs, bars etc. near the pulley, "V" belt, bobbin winder pulley, or motor when the machine is operation. Injury could result.
- 5) Do not insert fingers into the thread take-up cover, under/round the needle, or pulley when the machine is in operation.
- 6) If a belt cover, finger guard, and/or eye guard are installed, do not operate the machine without these safety devices.

### 2. Precaution before Starting Operation

- 1) If the machine's oil pan has an oil sump, never operate the machine before filling it.
- 2) If the machine is lubricated by a drop oiler, never operate the machine before lubricating.
- 3) When a new sewing machine is first turned on, verify the rotational direction of the pulley with the power on. (the pulley should rotate counterclockwise when viewed from the pulley.)
- 4) Verify the voltage and (single or three) phase with those given on the motor nameplate.

### 3. Precaution for Operating Conditions

- 1) Avoid using the machine at abnormally high temperature (35°C or higher) or low temperature (5°C or lower). Otherwise, machine failure may result.
- 2) Avoid using the machine in dusty conditions.
- 3) Avoid using the machine in areas where too much electrical noise, resulted from the high-frequency welder and others, is generated.

**PREPARATION FOR OPERATION**

Overall view of assembled sewing machine

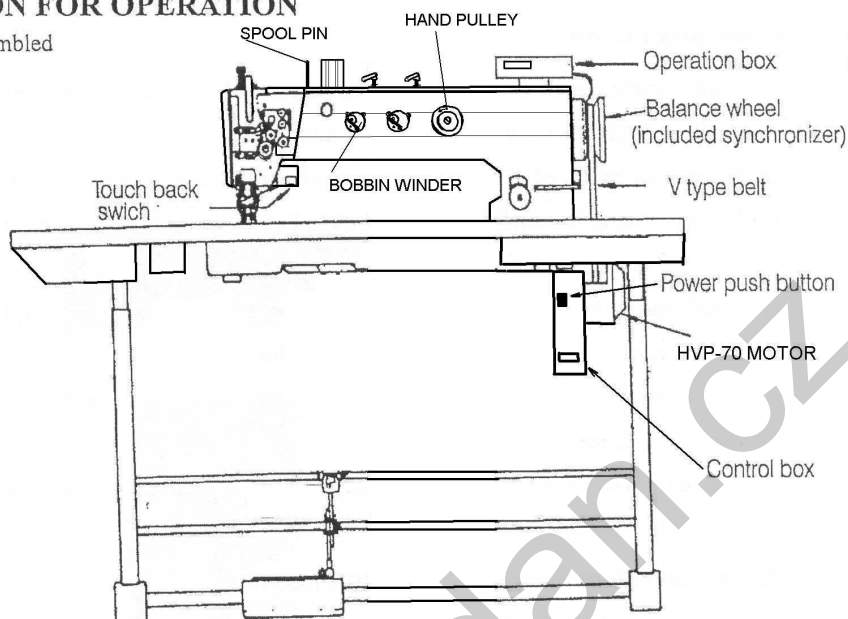

**1. Power cable connection**

**1) Connection to Power Supply**

When connecting the power supply connector to the control box, the connector should be completely plugged in the proper receptacle after confirming the connector type and matching direction.

- A. In case of three-phase electrical power system, the “U” phase should be connected to the red lead, the “V” phase to the white lead, and the “W” phase to the black lead. The motor rotary direction depends, however, upon the setting of the internal switch in the control box as described in Paragraph 1-(3)

**CAUTION: The green wire must be connected to the ground terminal in order to ground the motor properly.**

- B. The appropriate power fuse capacity is as follows. Power supply 200V-240V: 10A  
100V-120V: 15A

**2) Lamp Leads**

- A. When installing the illuminating lamp(6V,15-20W),The connecting wire is attached on the back of the Control box. It should be removed and connected by removing the insulating tube from the wire and stripping properly. The wire connections should be, then, insulated by

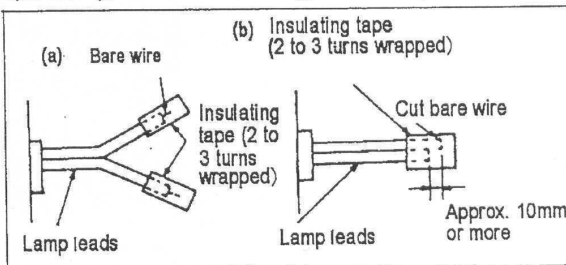

wrapping insulating tape on the wires.

**CAUTION: The power switch must be Turned off before connecting the lamp.**

- B. When the illuminating lamp is not used, the end of the lamp leads must be insulated as (a) or (b) as shown in the figure on right side. If a short circuit occurs failing to insulate, the transformer in the control box will be possibly burned out.

**CAUTION: The illuminating lamp must not be connected with any heater, such as a foot warmer and others, in parallel. Otherwise, the load capacity will be exceeded. It may cause transformer winding burned out.**

### 3) Rotary direction

It is possible to change the rotary direction of the motor by removing the rubber cap from the bottom left side of the front cover on the control box, and push the internal direction selector switch. The built-in lamp in the internal switch is off when the motor is rotating counterclockwise as facing to the motor pulley, and on when rotating clockwise. The rotary direction has been set to counterclockwise as facing to the motor pulley, matching with the machine prior to shipping

## 2. Connection of control box

The control box should be connected as shown to the right.

**Note: (1) Be sure to turn the power switch**

**off for safety before connecting or disconnecting the connectors.**

- (2) **The combination of the machine heads with the motor control panels are specified below.**

Use special care for the correct

combination when replacing the machine head or motor control panel.

## 3. Adjustment of needle bar stop position

- 1) Adjust of "UP" position

When the pedal is kicked down by heel, the machine stops at "UP" position. If the marks deviate larger than 3 mm, adjust as follows.

- a) Disconnect the plug (12 pins) of cable from the machine head.
- b) Run the machine and stop at "UP" position.
- c) While holding the pulley, insert the "adjusting

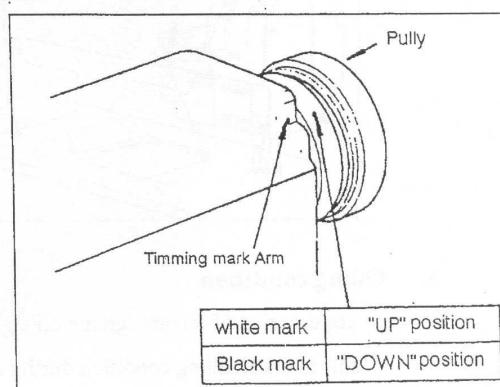

- tool" in the hole" A", then remove the tool.
- 2) Adjust of "Down" position  
When the pedal is "Neutral" the machine stops at "Down" position. If the marks deviate large than 5 mm, adjust as follows.
    - a) Disconnect the plug (12 pins) of cable from the machine head
    - b) Run the machine and stop at "Down" position.
    - c) While holding the pulley, insert the "adjusting tool" in the hole "B", then remove the tool.
  - 3) Confirm the stop operation, then set the plug (12 pins) coming from the machine head into the receptacle.

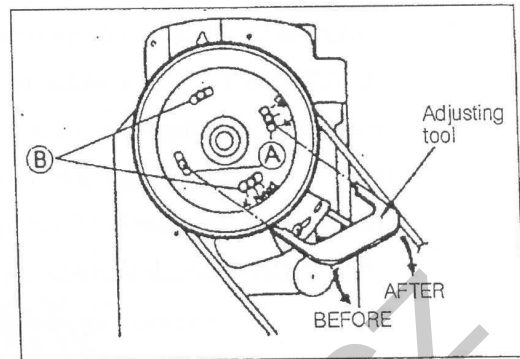

### CAUTIONS ON USE

#### 1. Oiling (1)

Fill the oil reservoir with oil up to "H" mark and more.

Oil level should be periodically checked. If oil level is found below "L" level replenish oil to "H" level. **For oil, Use white spindle oil.**

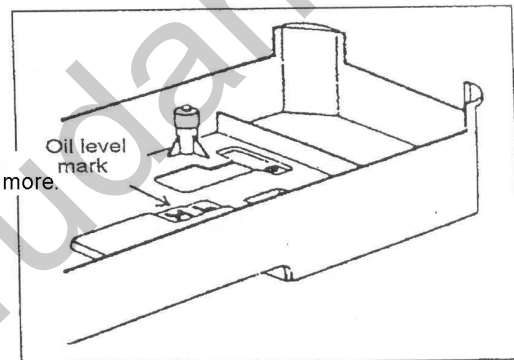

#### 2. Oiling (2)

When a new sewing machine is used for the first time, or sewing machine left out of use for considerably long time is used again, replenish a suitable amount of oil to the portions indicated by arrow in the below figure

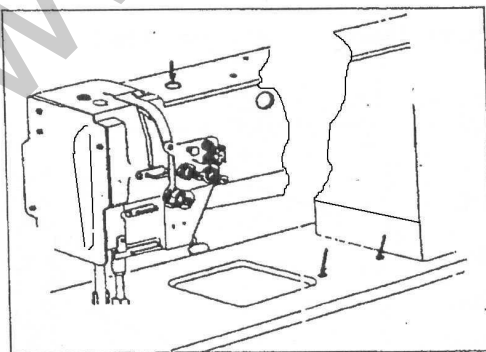
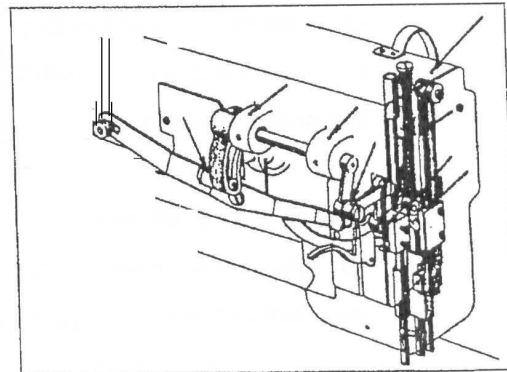

#### 3. Oiling condition

See dripping of oil through the oil sight hole to check oiling condition during operation.

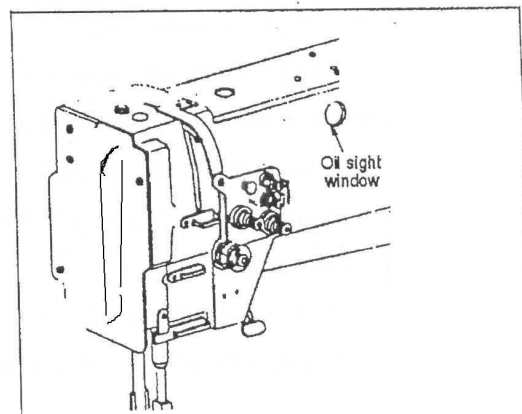

4. Adjustment of oiling to rotating hook

5. Cautions on operation

- a) When the power is turned on or off, keep foot away from the pedal.
- b) It should be noted that the brake may not work when the power is interrupted or power failure occurs during sewing machine operation.
- c) Since dust in the control box might cause malfunction or control troubles, be sure to keep the control box cover close during operation.
- d) Do not apply a multimeter to the control circuit for checking; otherwise voltage of multimeter might damage semiconductor components in the circuit.

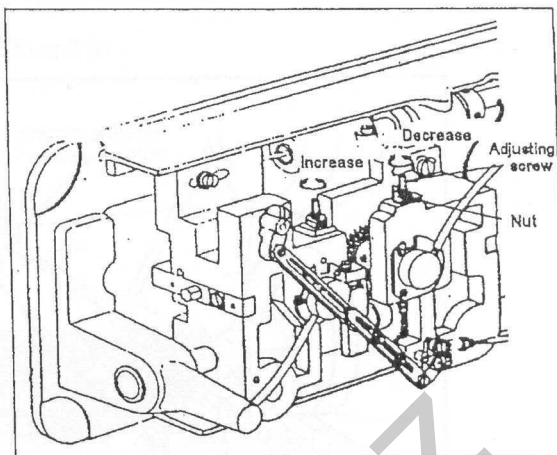

**OPERATION**

1. Installation of needles

Note: Before installing the needles, be sure to turn off the power.

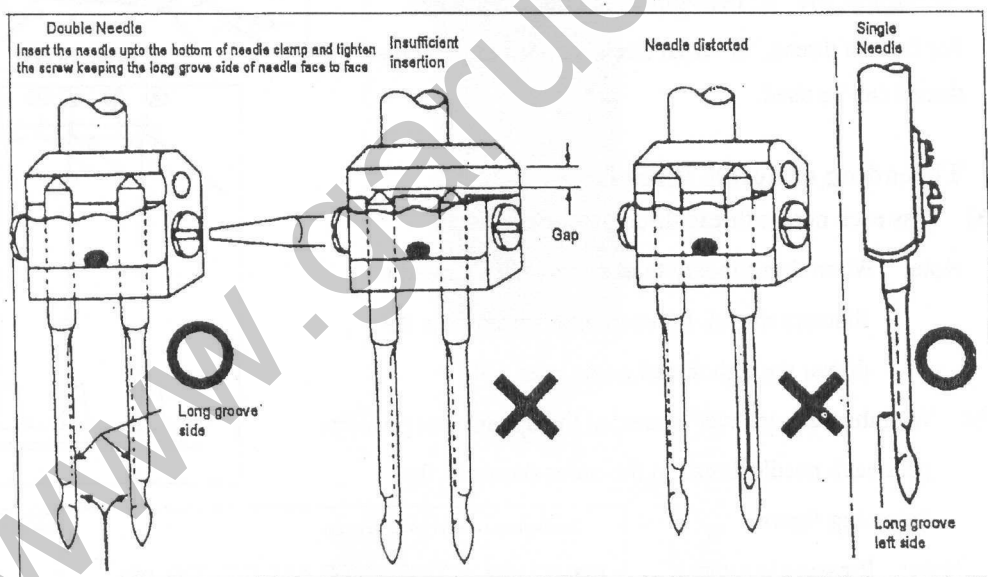

2. Winding of bobbin thread

Note: When bobbin thread is wound, keep the presser foot lifted.

Adjustment:

- |                         |  |
|-------------------------|--|
| Tension of wound thread | Slack winding is recommended for polyester thread and nylon thread.  |
| Conically wound thread  | Move the thread guide toward smaller diameter of wound thread layer. |
| Length of wound thread  | Loosen the thread length adjusting screw to increase length          |

of thread and tighten the screw to decrease length of thread.

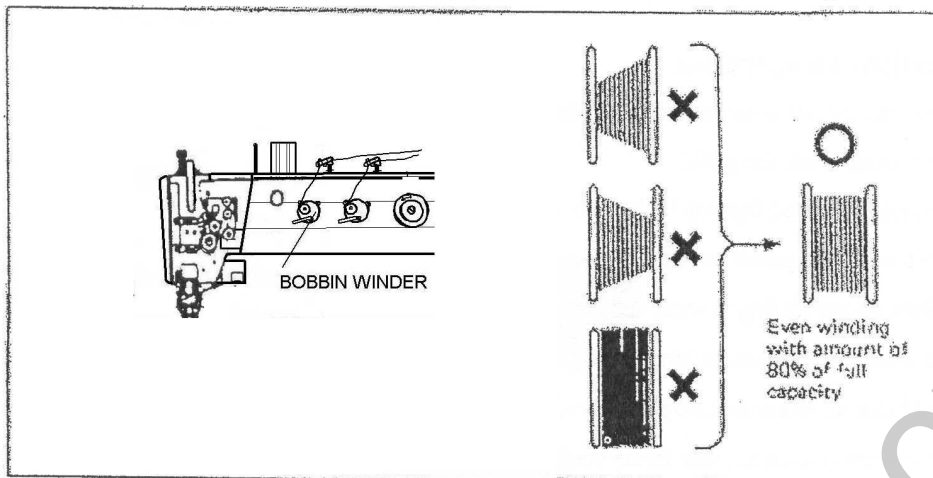

**3. Selection of thread**

It is recommended to use "S" twist thread in the left needle (viewed from front), and "Z" twist thread in the right needle. When discriminate use of needle threads is impossible, use "Z" twist thread in both the needles. For bobbin thread, "S" twist thread as well as "Z" twist thread can be used.

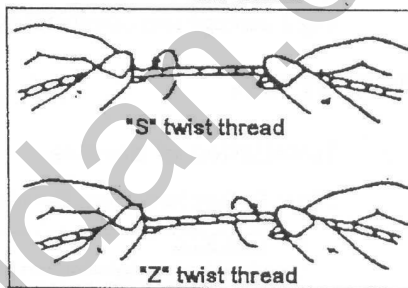

**4. Threading of needle threads**

- a) Pass each needle thread through thread guide A  
 Note: When thin slippery thread (polyester Thread or filament thread, for example) is used pass the thread through thread guide B as well.
- b) With the take-up lever located at the upper most position, pass each needle thread in the order shown in the following figure.

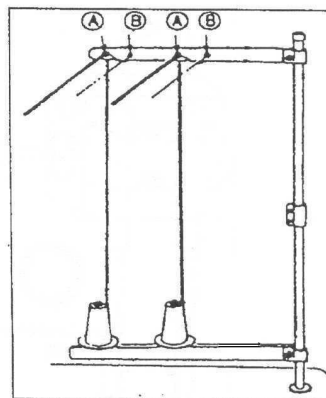

Note: Pressing the upper thread loosening button shown in the figure below opens the saucer of the upper thread tension adjuster, and the upper thread can easily pulled out.

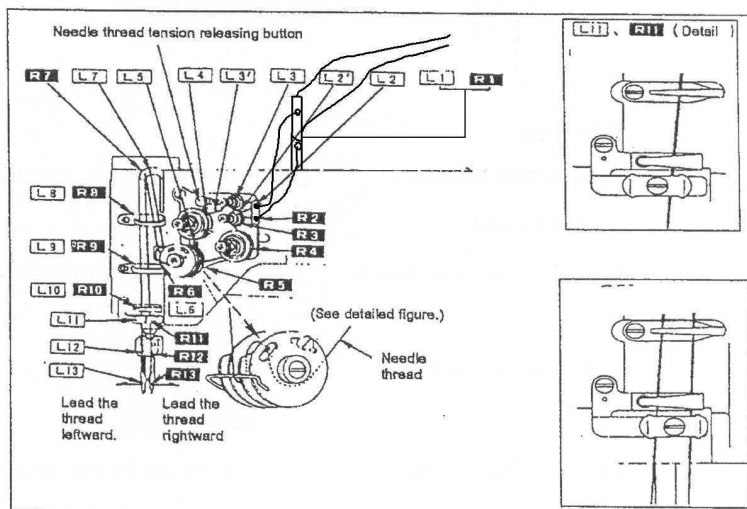



## 5. Adjustment of feed (stitch) length and stitch reversing (touch back)

**Note:** To make feed (stitch) length smaller, depress the feed reverse lever and set the feed length setting dial to a desired position

Touch-back button . . . Direction of stitching can be reversed by depressing this button. Stitching goes on in reversed direction while the button is held down, and returns to forward direction when the button is released. .

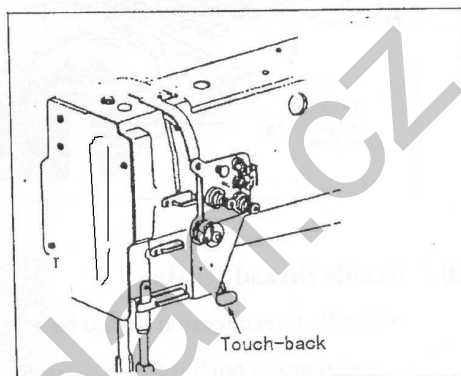
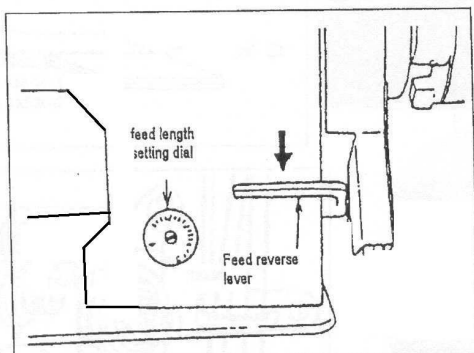

## 6. Setting of bobbin

- Pulling out 5.cm thread tail from the bobbin.
- Hold the bobbin so that the bobbin thread is would in right direction and put it into the hook.

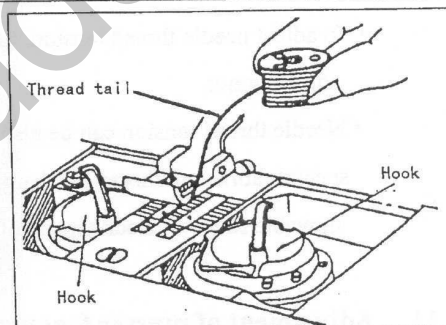

## 7. Threading of bobbin threads

- Put the hook into the bobbin case and press down the latch ①. The thread end should be left on the bed .
- While holding the two needle Threads by left hand, rotate the hand-wheel one turn by right hand.

By pulling up the needle threads, as shown in the figure, the bobbin threads will be lifted. Each combination of bobbin thread and needle thread should be aligned and led backward.

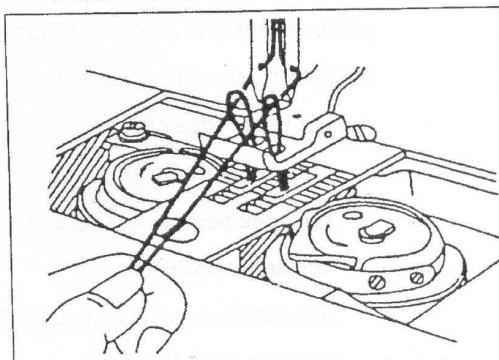
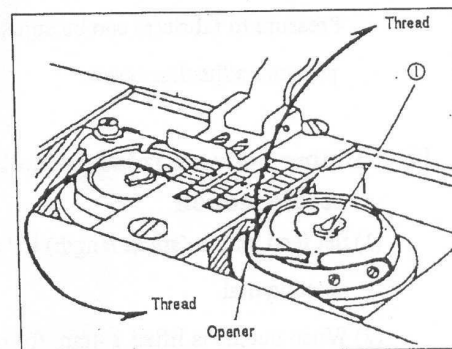

**8. Tension adjustment of bobbin threads**

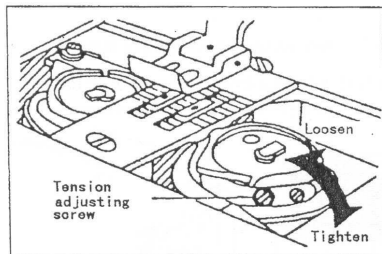

**9. Balance of thread tension**

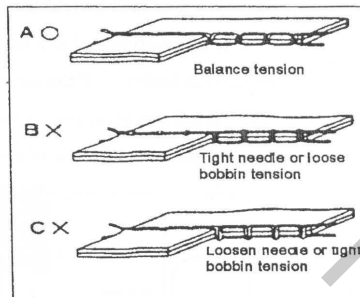

**10. Needle thread tension**

- Needle thread tension should be adjusted in reference to bobbin thread tension.
- To adjust needle thread tension, turn each tension adjusting nut.
- Needle thread tension can be also adjusted for special fabric and thread by changing intensity and movable range of slack thread adjusting spring.

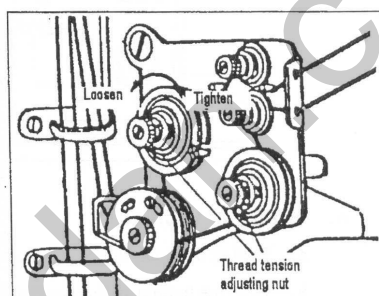

**11. Adjustment of presser foot pressure**

Pressure to fabric(s) can be adjusted by turning the pressure adjusting screw.

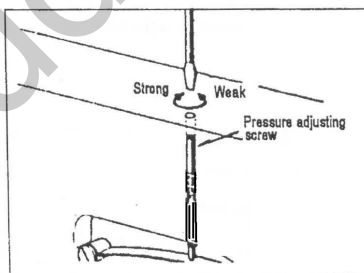

**12. Timing between rotating hook motion and needle motion**

- (1) Set feed length (stitch length) to "6" on the feed setting dial.
- (2) When needle is lifted 2.4mm from the lower dead point, as shown in Figure, the following positional relationship should be maintained.
  - The upper edge of needle eye should be 2.3mm below the hook point.
  - The hook point should be located at the center of needle axis.
  - Gap between the hook point and the side face of needle should be 0.05mm.

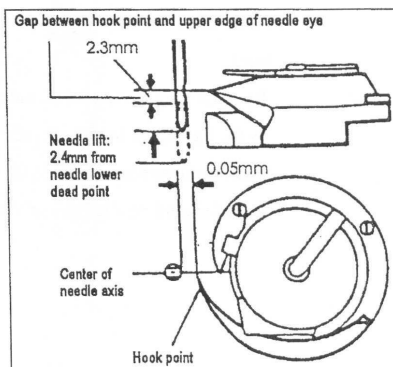

■ **Positioning of hook point**

- (1) When the needle is at DOWN position, the smaller Crossed helical gears on the right side and left side should be engaged with the large wheel so that the "S" screw of the former gear comes on the front side, and that of the latter gear on the reverse side.
  - (2) Tighten each "S" screw, where is punched for set screw, on the hook shaft.
  - (3) Approximate position of hook "C" screw of hook should be found close to the needle when the needle is at DOWN position.
- ◆ To finely adjust timing between the needle motion and hook motion, loosen the set screw of larger gear wheel and move the gear wheel in its axial direction within a range from 1mm to 2mm.

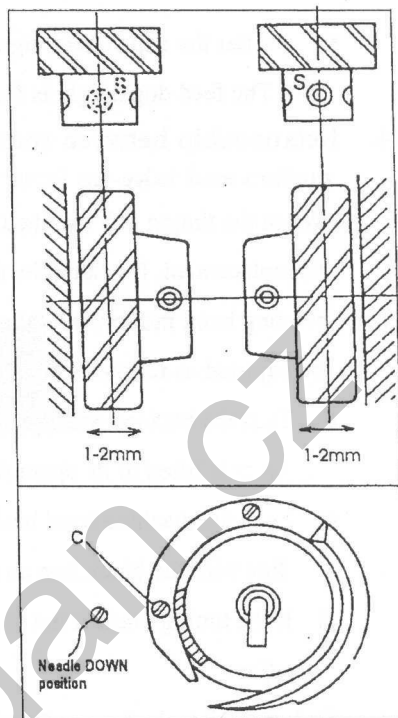

**13. Adjustment of feed dog height**

Height of feed dog and pressure of presser foot should be adjusted for individual fabric(s) with the following cautions:

- Fabric will be damaged if the feed dog extends too high, or pressure of presser foot is too large.
- Even stitch length cannot be assured if the feed dog is too low or pressure of presser foot is too small.
- Feed dog height should be measured at the point where the needle is at the top position.

For light fabrics ..... Approx. 0.8mm from throat plate  
 For usual fabrics ..... Approx. 1.0mm from throat plate  
 For heavy fabrics ..... Approx. 1.2mm from throat plate

**Adjustment procedure**

- a) Lean the machine head backward.
- b) Turn the hand wheel by hand and stop when the feed dog rises to the maximum height.
- c) Loosen the feed bar set screw.
- d) Vertically move the feed bar (in the direction indicated by arrow in the figure) to adjust it to adequate height.

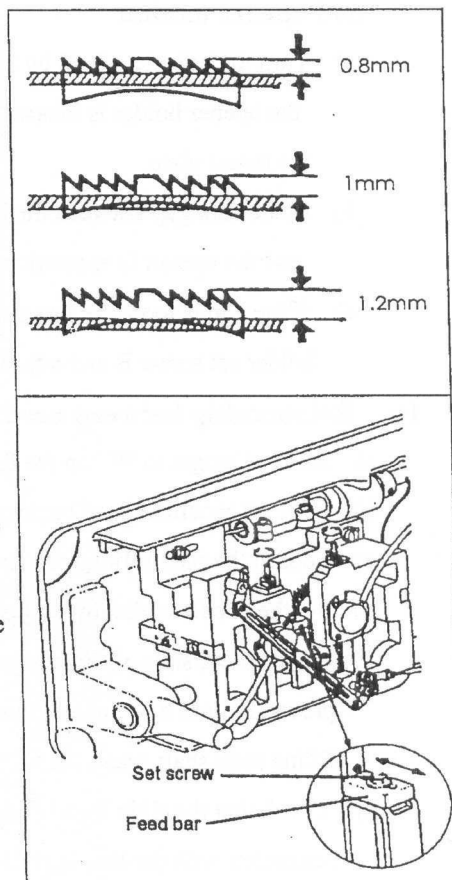

- e) After the adjustment, tighten the feed bar set screw.  
 ♦ The feed dog height is factory-adjusted to 1.2mm

#### 14. Relationship between rotating hook motion and take-up lever motion

When the timing belt (toothed belt) was removed for its replacement, for example, the relationship between rotating hook motion and take-up lever motion should be adjusted as follows:

- Turn the balance wheel and stop when the take-up lever is lifted to its upper dead point.
- Lean the machine head backward and make sure the arrow (timing mark) put on the timing belt is in line with the black line on the boss of lower shaft bearing.
- If the timing mark is not in line with the black line, remove the timing belt and install it again to adjust.

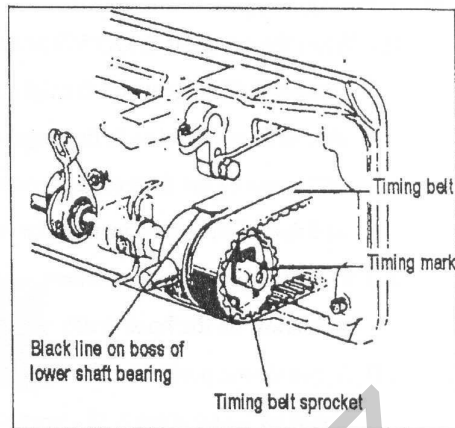

#### 15. Relationship between hook motion and opener motion

- Turn the balance wheel by hand and stop when the opener holder is located most remotely from the throat plate.
- Make sure gap between the bobbin case holder A and the opener is approximately 0.2mm.
- If the gap is too large or small, loosen the opener holder set screw B and adjust position of the opener.

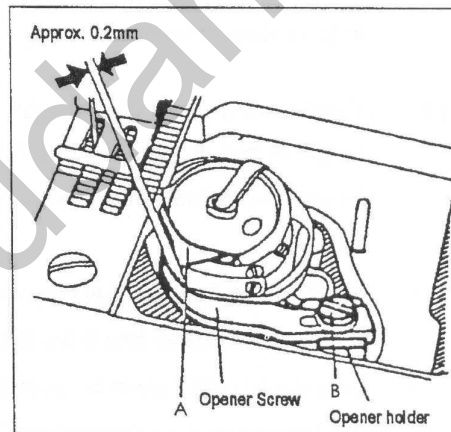

#### 16. Relationship between needle motion and feed dog motion

- Set feed length to "0" on the feed setting dial
- Lean the machine head backward.
- Loosen the feed lifting rock shaft crank set screws A and B
- Set the needle at the lowest position.
- Adjust the distance between presser rod and vibration prevention rod to 9mm and temporarily tighten the feed lifting rock shaft crank set screws A and B
- Check that the right feed lifting rock shaft crank is connected with the link at right angle, as shown in Figure.
- If the connection is not at right angle, remove the back cover, loosen screw C and move the right link to connect the right feed lifting rock shaft with the link at right angle.

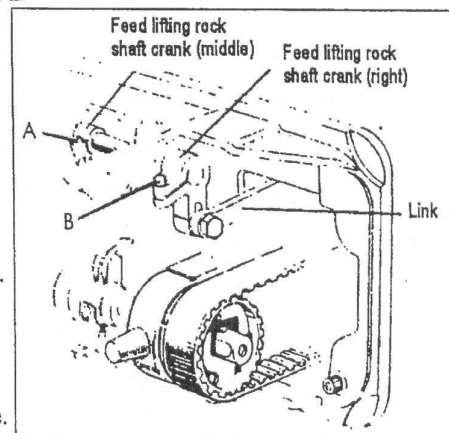

h) After the completion of adjustment, fully tighten the screws A, B and C.

- ♦ At this time make certain that needle can enter the feed dog needle hole at the center of the hole.

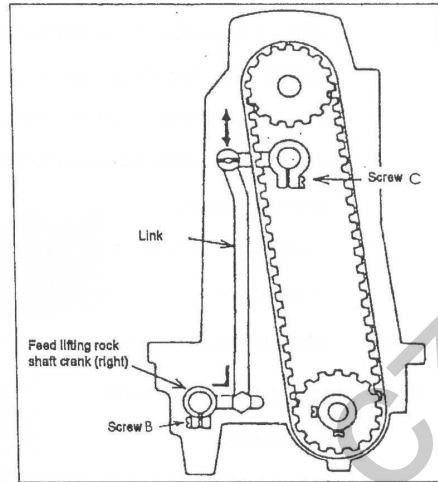
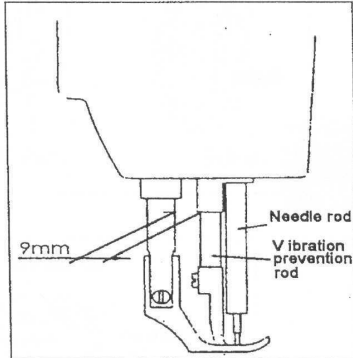

**17. Safety clutch device:**

Safety clutch device is installed to prevent the hook and cog belt from damage in case the thread is caught into the hook when the machine is loaded abnormally during operation.

**(1) Function of safety clutch.**

- a) When the safety clutch acts, the cog belt pulley will be unloaded. then the rotation of hook shaft will stop. The arm shaft only will rotate. Stop the operation of machine.
- b) Clean the thread thoroughly which is caught into the hook.
- c) Turn the cog belt hub by hand, and check whether the hook Shaft rotates lightly and properly, place the clutch device as follows.

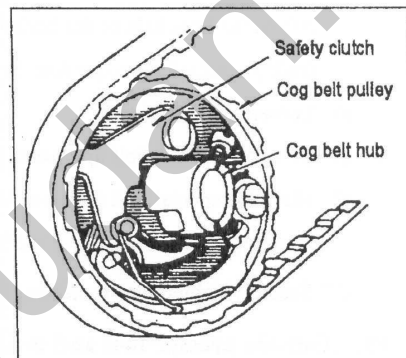

**(2) How to set the safety clutch.**

- a) While pressing down the push button on the opposite side of bed by left hand, turn the balance wheel slowly by right hand away from you as shown in the figure.
- b) The balance wheel will stop by the gear plate, but turn the balance wheel more firmly.
- c) Release the push button.
- d) As shown in the Figure, the safety clutch device is set.

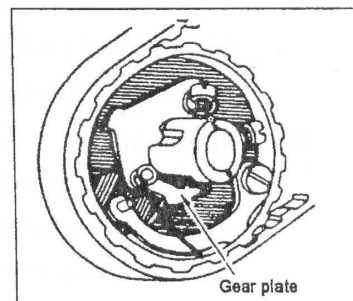
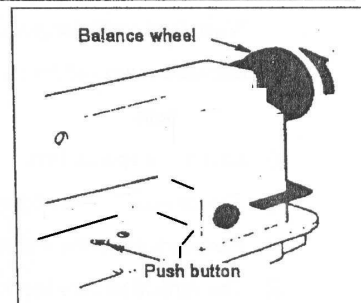

**(3) Force applied to the safety clutch.**

- The force applied to the safety clutch is the smallest when the white mark of the eccentric pin faces the center of the lower shaft. The force proportionally increases as the white mark faces the outside.
- To adjust the force slide the timing belt, loosen the set screw, and turn the eccentric pin.
- After the adjustment, make sure to fasten the set screw.

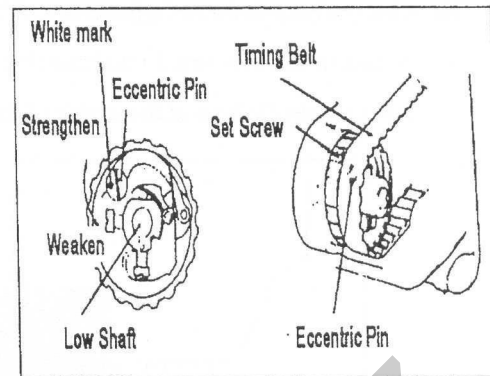
**18. Upper feed adjustment****(Needle side)**

If the uneven feeding occurs according to the fabric, Adjust the long hole of the horizontal feed shaft crank (right) to adjust the upper feed length. (How to adjust)

- Loosen the special bolt.
- Move the special bolt upward to decrease upper feed.
- Move the special bolt downward to increase the upper feed. The upper feed and the lower feed theoretically becomes equal at the reference line on the horizontal feed shaft crank.
- Securely tighten the special bolt after adjustment.

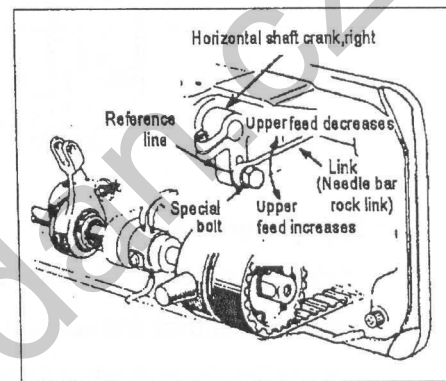
**19. Outside presser foot and inside presser vertical stroke adjustment**

When fabric with large elasticity is sewn, or when thickness of fabric changes, the vertical stroke (movable range) of the presser feet should be adjusted as follows:

**Adjustment**

- Loosen the special bolt.
- The vertical strokes of the presser feet become
- maximum when the crank rod is moved upward and set.
- The vertical strokes becomes minimum when the nut is moved downward and set.
- After the adjustment, fully tighten the special bolt.

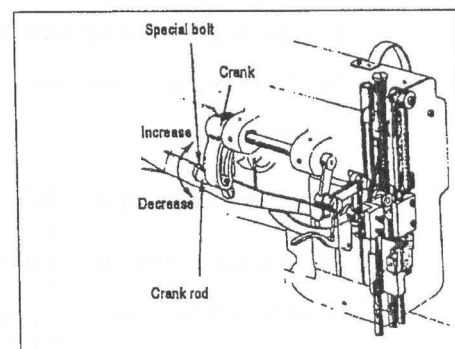

- The vertical strokes of the presser feet can be adjusted within a range from 6mm to 2mm.

**20. Adjustment**

Screwing the pin that connects the link of back-sewing with the crank of back-sewing (down) can adjust the tolerance of between the stitches. Screwing the pin in clockwise can increase the stitch of forward sewing; otherwise, the stitch of back-sewing will be increased.

## 21. Installation of movable knife

### (1) Installation of movable knife

- Turn the balance wheel and lower the needle bar to the lowest position.
- Push the cam follower crank so that the cam roller enters into the thread trimmer cam groove.
- Turn the balance wheel until the black mark point on the arm meets the white mark point on the balance wheel. Set the cam follower crank at this position with a screwdriver temporarily preventing the cam roller coming out from the cam groove.
- Loosen the thread trimmer rocking crank clamp bolts A and B.
- Adjust the movable knife so that the movable knife end slant portion protrudes 0-0.5 mm from the fixed knife, as shown in Figure and tighten the bolts A and B.

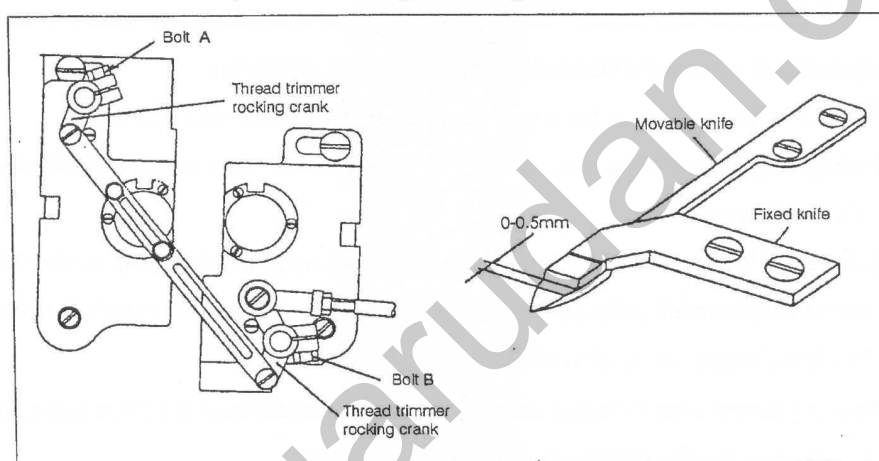

### (2) Gap between movable knife and bobbin case holder stopper

- Turn the balance wheel by hand until needle reaches the lowest position.
- With the needle at the lowest position, depress cam follower crank, turn the balance wheel until the movable knife reaches the extremity of its stroke.
- Manually rotate the inner hook in the direction indicated by arrow in Figure and adjust gap between the movable knife and the inner hook stopper to about 0.5 mm (the screws A and B should be loosened for this adjustment).

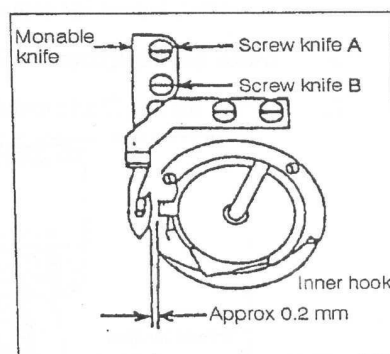

## 22. Adjustment of thread trimmer cam

- Turn the balance wheel by hand until the needles reach the lowest position.
- Maintaining the needle position, depress the cam follower crank and put the cam roller into the groove of thread trimmer cam.
- Turning the balance wheel by hand, adjust the thread trimmer cam so that the movable knife starts moving when the green mark point on the balance wheel comes in line with the black mark point on

the arm.

**Note:** To adjust, loosen two thread trimmer cam clamp screws A.

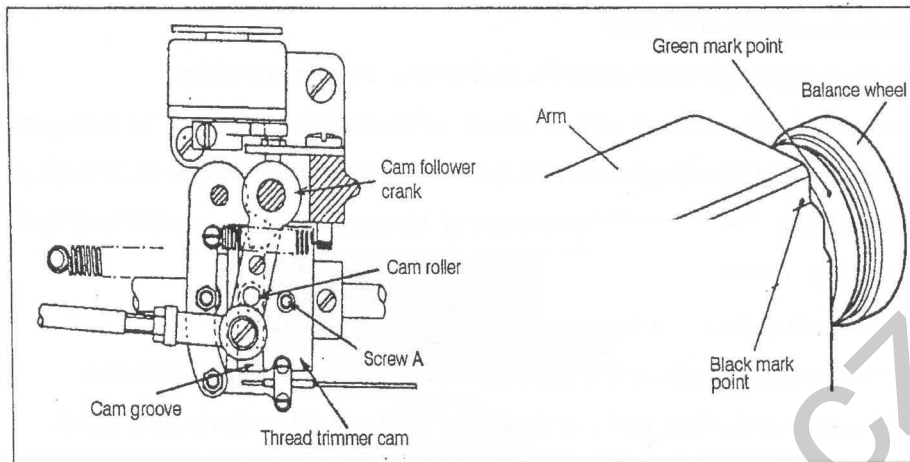

### 23. Adjustment of needle threads tension release assembly

- Turn the balance wheel by hand until the needles reach the lowest position.
- Maintaining the needle position, depress the cam follower crank and put the cam roller into the groove of thread trimmer cam.
- Turning the balance wheel by hand, adjust the thread tension release cam so that the tension disc close when the white mark point on the balance wheel comes in line with the black mark point on the arm. To adjust, loosen two tension release cam clamp screws A.
- Opening degree of tension disc should be adjusted with the tension release roller B mounted on the convex portion of thread release cam, as shown in Fig. To adjust, loosen the screws C and draw the wire.
- Make fine adjustment by loosening the nut D.
- Loosen the nut D and make the outer casing approach rightward to increase the opening value.

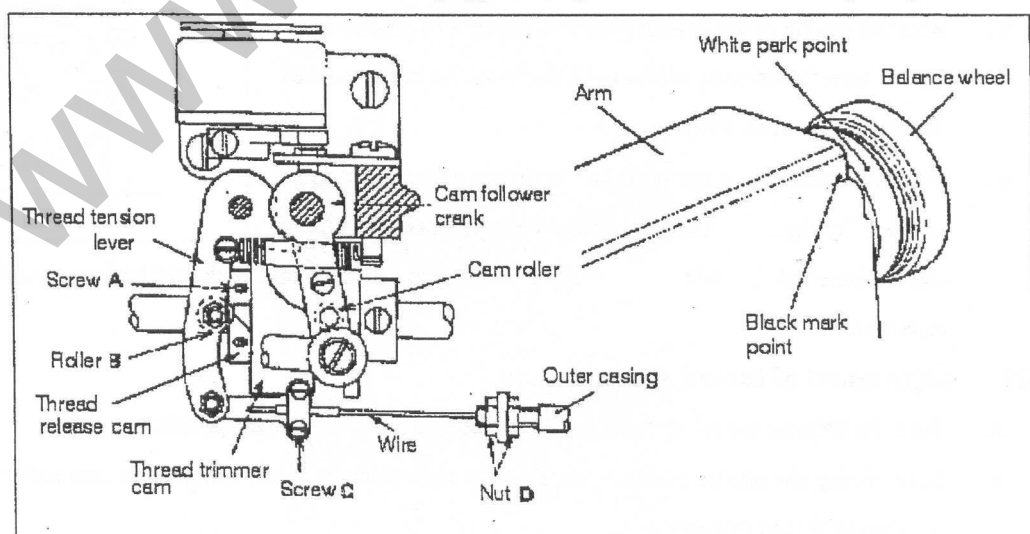

### 24. Adjustment of scissoring pressure of movable knife and fixed knife

- Loosen the fixed knife bracket clamp bolt A.



- b. Turn the vertical position adjusting screw B to adjust meshing pressure and then tighten the hexagon socket head cap screw A.

**Note:** Since excess pressure causes large torque to the thread trimming mechanism and trimming failure, adjust it so that thread can be trimmed with minimum pressure.

- c. Move the movable knife and check that the thread can be sharply trimmed.

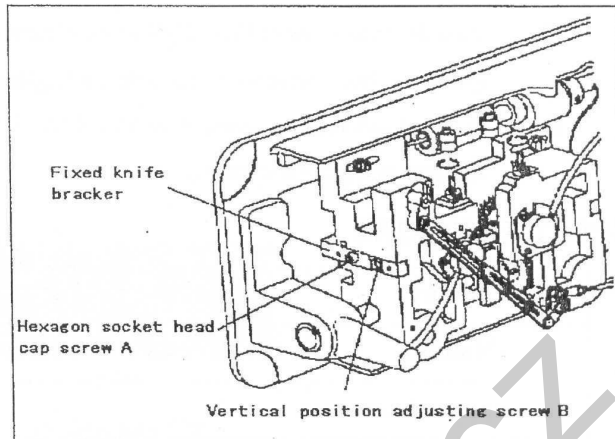

**25. Sharpening of fixed knife**

When the knives dull, the fixed should be sharpened as illustrated in Fig. Since it is very difficult to sharpen the movable knife, replace it with a new one when it dulls.

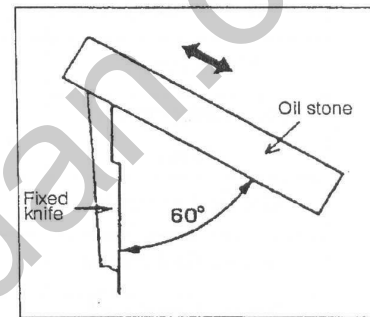

**26. Adjustment for change of needle-to-needle distance**

- (1) Replace the throat plate, feed dog and needle clamp.  
(Since the throat plate and feed dog are special parts designed for thread trimming machine, be sure to use those specified by us.)

- (2) Lean the machine head backward.
- (3) Loosen two connecting link clamp bolts J.
- (4) Remove the spring M.
- (5) Loosen the hook bracket clamp screws A and B and adjust gap between each needle and hook.
- (6) When the needles and hooks have been adjusted, install the spring M.

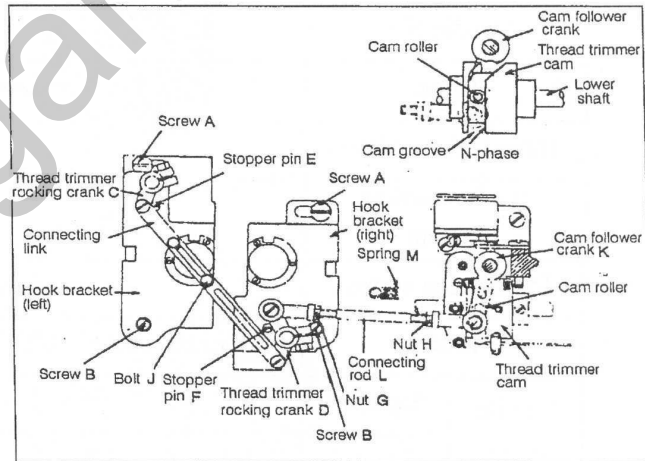

- (7) Contact the rocking cranks C and D to the stopper pins E and F and tighten the connecting link clamp bolt J.
- (8) Turn the balance wheel by hand until the needles reach the lowest position.
- (9) Loosen the nuts G and H.
- (10) Depress the cam follower crank K and adjust the connecting rod L so that the cam roller can smoothly enter the groove of thread trimmer cam.
- (11) Adjustment of the cam groove and the cam roller

- a. Push the cam follower crank K so that the cam roller enters into the cam groove.
- b. Turn the connecting rod L and adjust the clearance between the cam roller and the cam groove surface L as small as possible, and tighten the nuts G and H.
- c. Push the cam follower crank K again and check that the cam roller enters into the thread trimmer cam groove smoothly.

## SPECIFICATIONS

Model	GF-130-443 H	GF-230-443 MH	GF-130-446 H	GF-230-446 MH					
Number	Single-needle	Double-needle	Single-needle	Double-needle					
Application	Heavy material								
Max. sewing speed	2000(rpm)								
Stitch length	0~9(mm)								
Thread take-up lever stroke	74.5(mm)								
Needle-bar stroke	36(mm)								
Presser-foot stroke	16(mm) by Leg		8(mm) by hand						
Vertical stroke of upper feed	2~6(mm)								
Needle No.	DP×17 #23								
Hook	(Horizontal full-rotating) Large								
Thread take-up lever	Slide lever								
Stitch adjusting system	Dial								
Lubrication system	Automatic lubrication								
Motor	HVP-70 (750W)		HVP-70 (750W)						
Needle gauge	Standard	6.4(mm)							
	Special	3.2	4	4.8	8	9.5	12.7	16	19

- Note:**
- ◆ Some materials, gauge sizes, and/or sewing conditions may require specifications other than those listed above.
  - ◆ Feed dog, throat plate, rotating hook, bobbin case and bobbin should be those designed for thread timer.
  - ◆ Bobbin should be of high quality free from deformation.
  - ◆ This specification is subject to change for machine improvement.