

Katalog ND pro průmyslový
šicí stroj

GARUDAN®

GZ-527 serie



ANITA B s.r.o.

Hliníky 2068

680 01 Boskovice

Czech Republic

fax: +420 516 452 751

tel: +420 516 454 774,

+420 516 453 496

e-mail: info@anita.cz

OBSAH : - Contents:
Dílce hlavy - Parts of head

tab.1

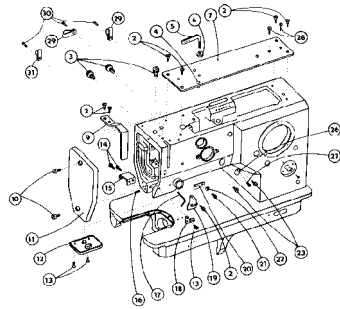

tab.2

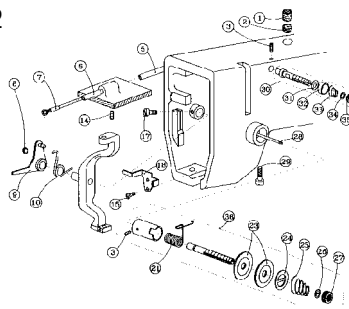

tab.3

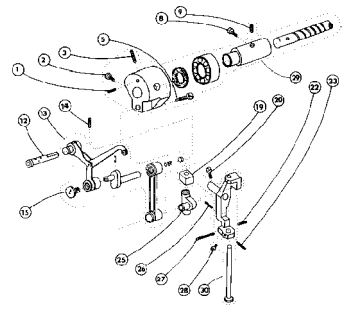

tab.4

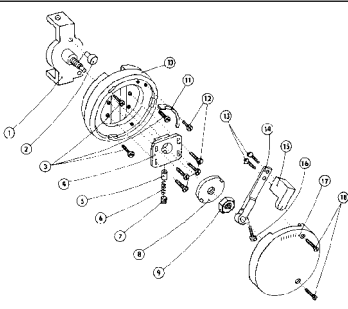

tab.5

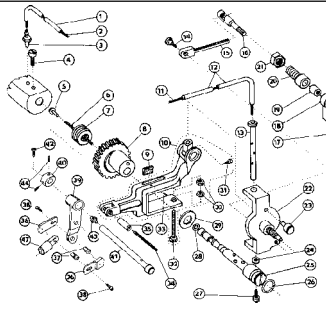

tab.6

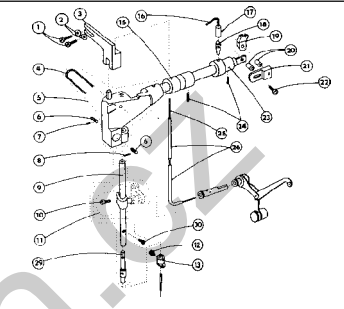

tab.7

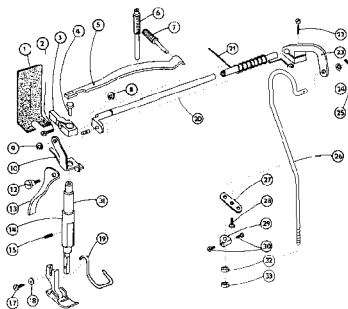

tab.8

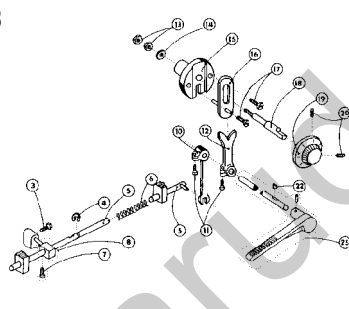

tab.9

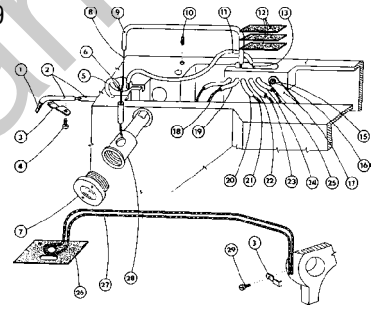

tab.10

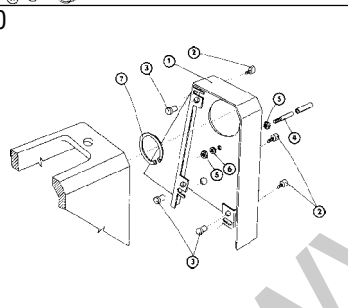

tab.11

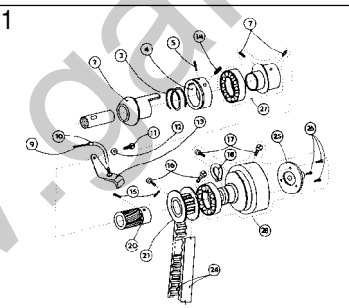

tab.12

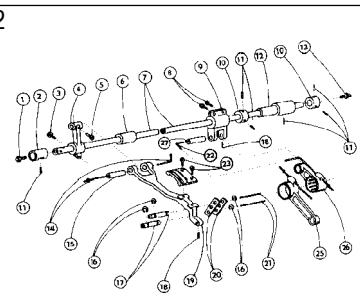

tab.13

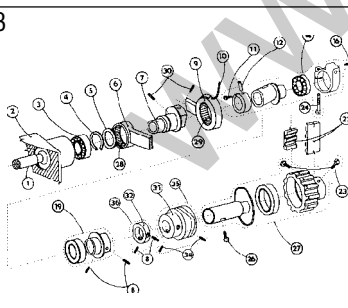

tab.14

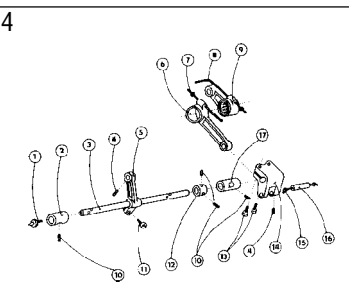

tab.15

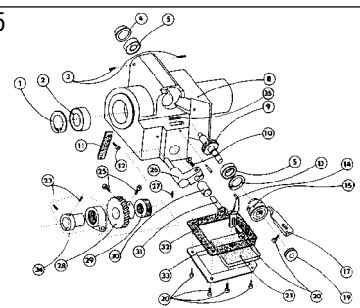

tab.16

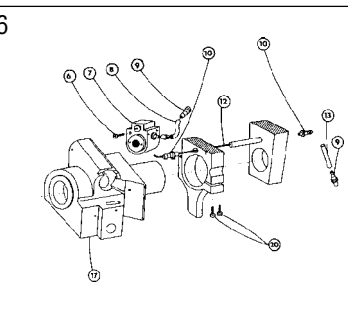

tab.17

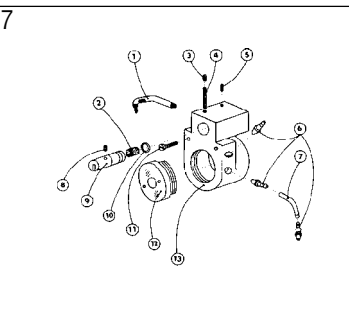

tab.18

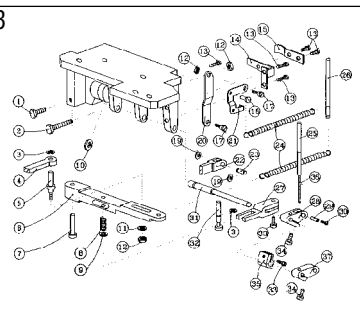

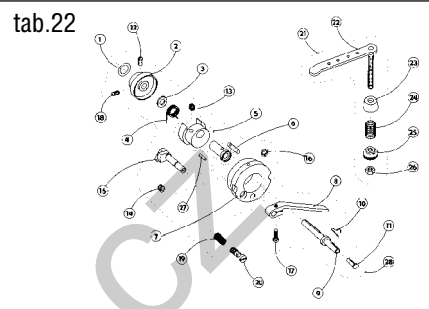
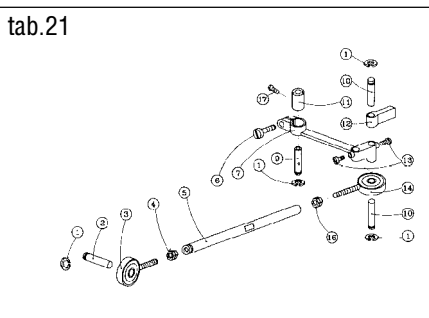
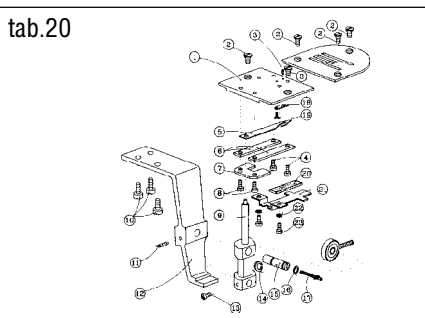
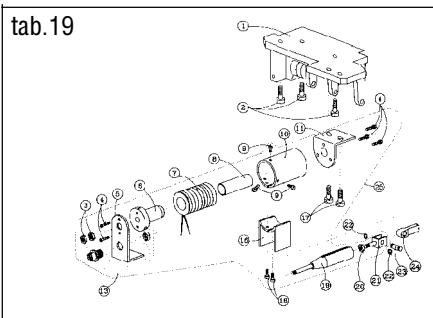

Číslo tabulky Table No.	Objednáací číslo Ordered No.	Název objektu Denomination
tab. 23	S980 008251	Chapač Hook
Příbal - Enclosed accessories		
tab. 24	S980 099038	Standard
tab. 25	S980 099038	Standard
tab. 26	S980 099038	Standard
tab. 27	S980 099038	Standard
tab. 28	S980 099038	Standard
tab. 29	S980 092229	Standard
Nutné vybavení - Necessary equipment		
tab. 30	S980 094051	Standard
tab. 31	S791 995068	Standard
Šicí vybavení - Sewing equipment		
Tabulka šicích vybavení - Table of sewing equipments		
tab. 32	S791 124061 35	Standard
tab. 33	S791 400023	
tab. 34 - tab. 35	S791 430048 35	
tab. 34 - tab. 35	S791 430060 35	
tab. 34 - tab. 35	S791 430061 35	
Volitelné vybavení - Optional equipment		
tab. 36	S791 149001	Vybavení pro obnitkování okrajů Attachment for serging operation
tab. 37	S791 151017	Otevřená patka Hinged foot with front thread slit
tab. 38	S791 995153	Zvedání patky elektromagnetem Presser foot lift via electromagnet
tab. 39 - tab. 40	S791 995154	Zpátkování elektromagnetem Backtacking via electromagnet
tab. 39	S980 094057	Tlačítko pro zpátkování, pro motor EFKA DA82GA Push button for backtacking, for EFKA motor DA82GA
tab. 39	S980 094060	Tlačítko pro zpátkování, pro motor EFKA 6F82FA Push button for backtacking, for EFKA motor 6F82FA
tab. 41	S791 947001	Ustavovací přípravek Adjustment gauges
tab. 42	S741 410504 40	Sada rychlepotřebitelných náhradních dílů High mortality spare parts kit
tab. 43	S791 430055 35	Chapač pro jehly 140-160 Nm Hook for needle size 140-160 Nm
tab. 44	S794 222012	Návěsné osvětlení Sewing lamp

527 - 105

2	S080	123117
3	S321	001000
4	S080	840073
5	S080	313204
6	S080	161138
7	S080	815007
9	S080	831348
10	S080	120248
11	S080	721173
12	S080	827180
13	S080	123122
14	S080	126063
15	S080	823149
16	S080	111227
17	S080	271184
18	S080	821115
19	S080	821077
20	S080	821113
21	S080	120361
22	S080	190368
23	S080	132112
26	S080	831494
27	S080	123166
28	S080	132153
29	9840	120030
30	S080	120331
31	9840	120028

tab. 1

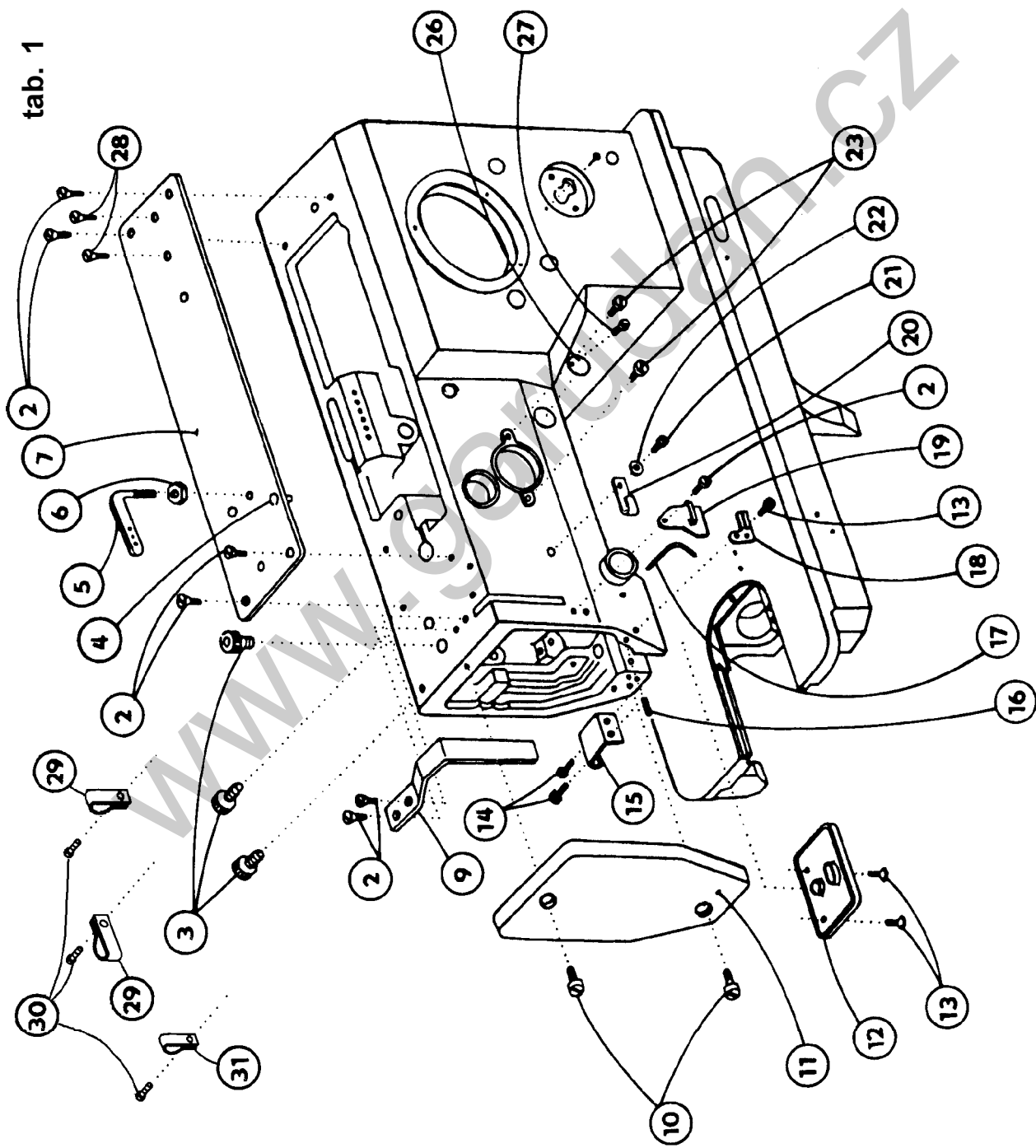

tab. 2

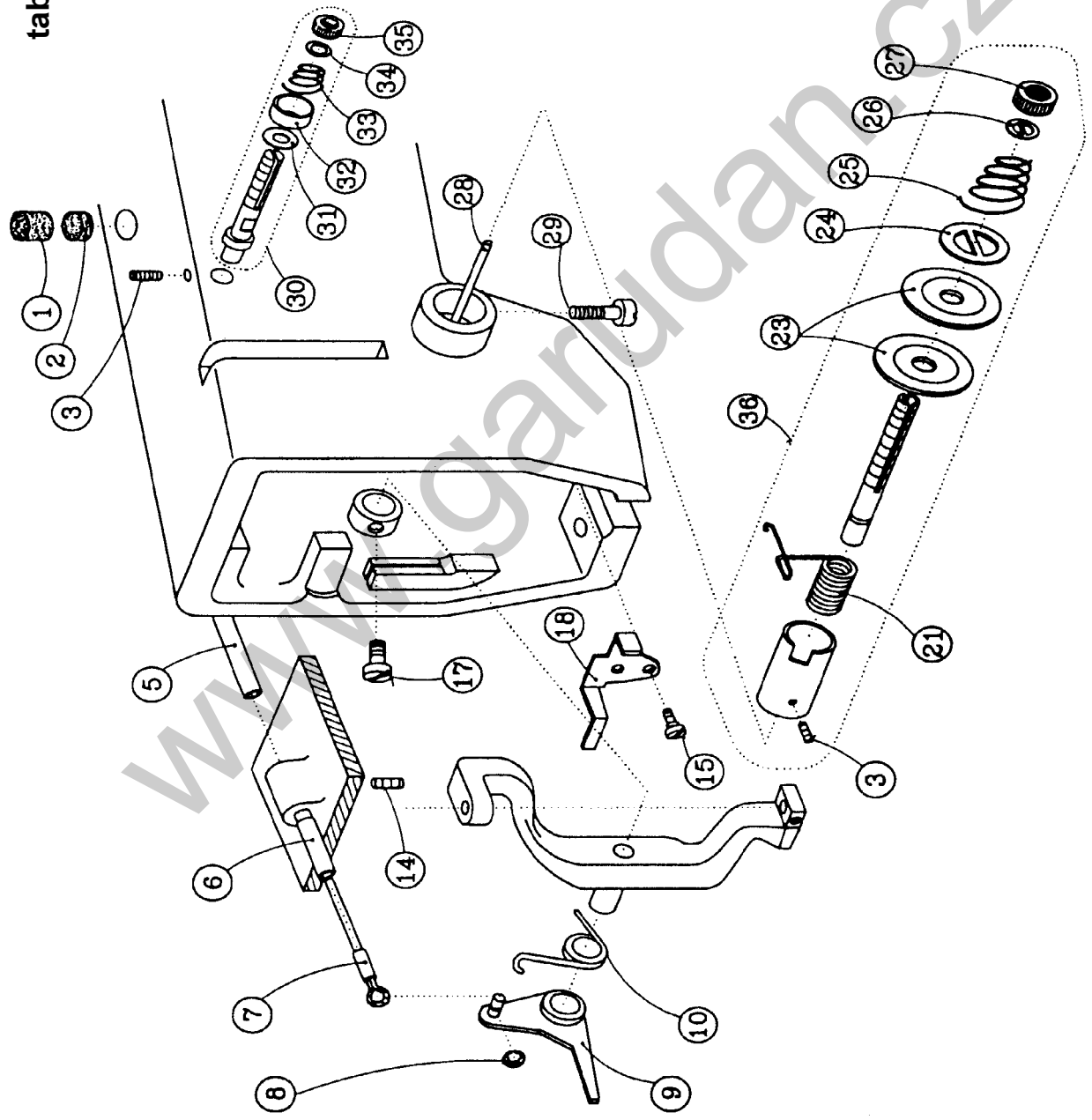

527 - 105

1	S080	945188
2	S080	945100
3	S080	111227
5	S080	278009
6	S080	410511
7	S980	049786
8	S080	274104
9	S980	049806
10	S080	264274
14	S080	111245
15	S080	131027
17	S080	120248
18	S080	822424
21	S315	264294
23	S080	828079
24	S080	828080
25	S080	262074
26	S080	195041
27	S080	171037
28	S080	310428
29	S080	120246
30	S980	025160
31	S080	828051
32	S080	827174
33	S080	262065
34	S081	200025
35	S080	171030
36	S980	025244

527 - 105

1	S080	111238
2	S080	122007
3	S080	112015
5	S080	138009
8	S080	120006
9	S080	953139
12	S080	328005
13	S980	044727
14	S080	112014
15	S080	120062
19	S080	953159
20	S080	120248
22	S080	111214
23	S080	111295
25	S080	452047
26	S080	111273
27	S080	111126
28	S080	120216
29	S980	043343
30	S980	035318

tab. 3

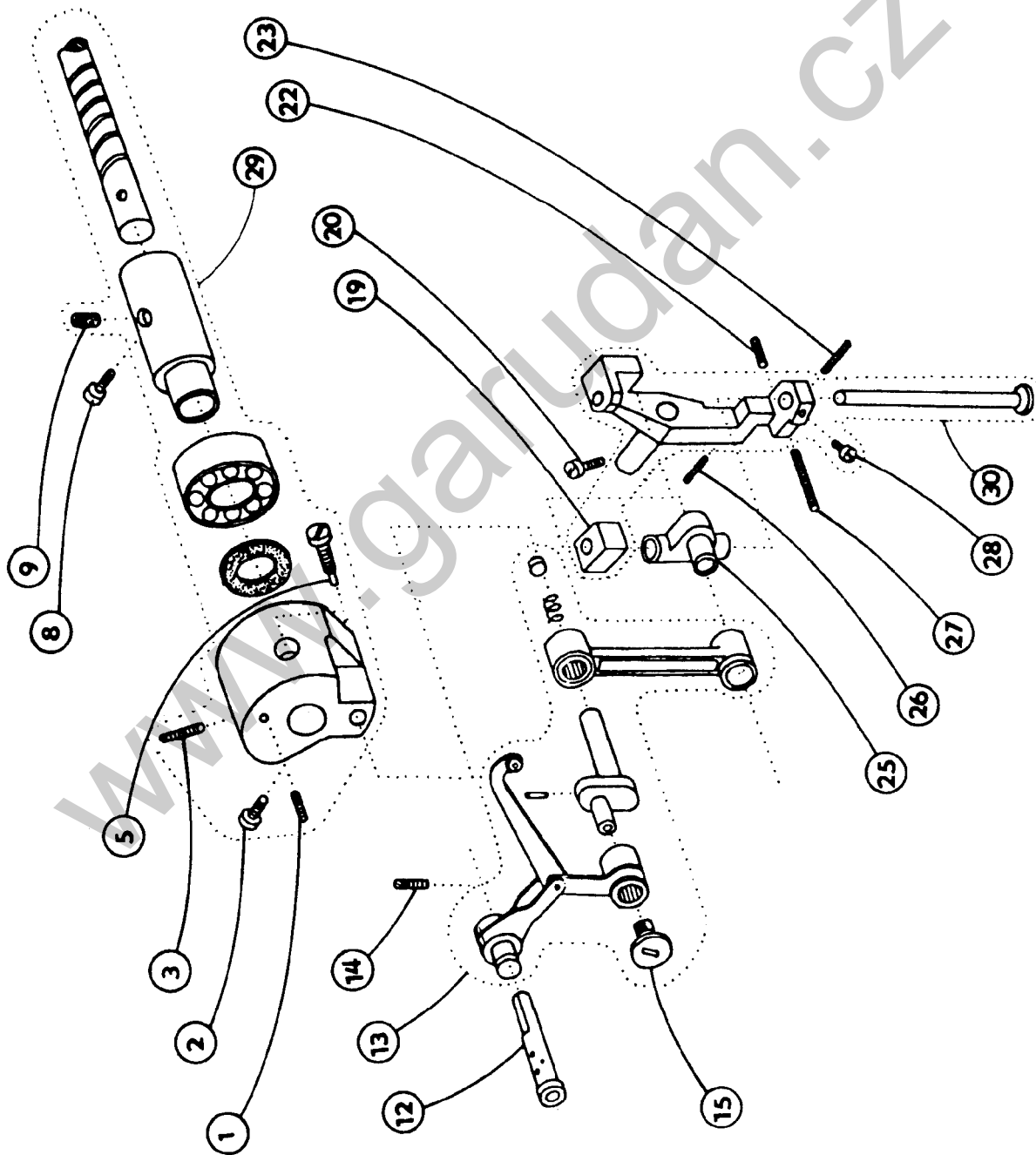

tab. 4

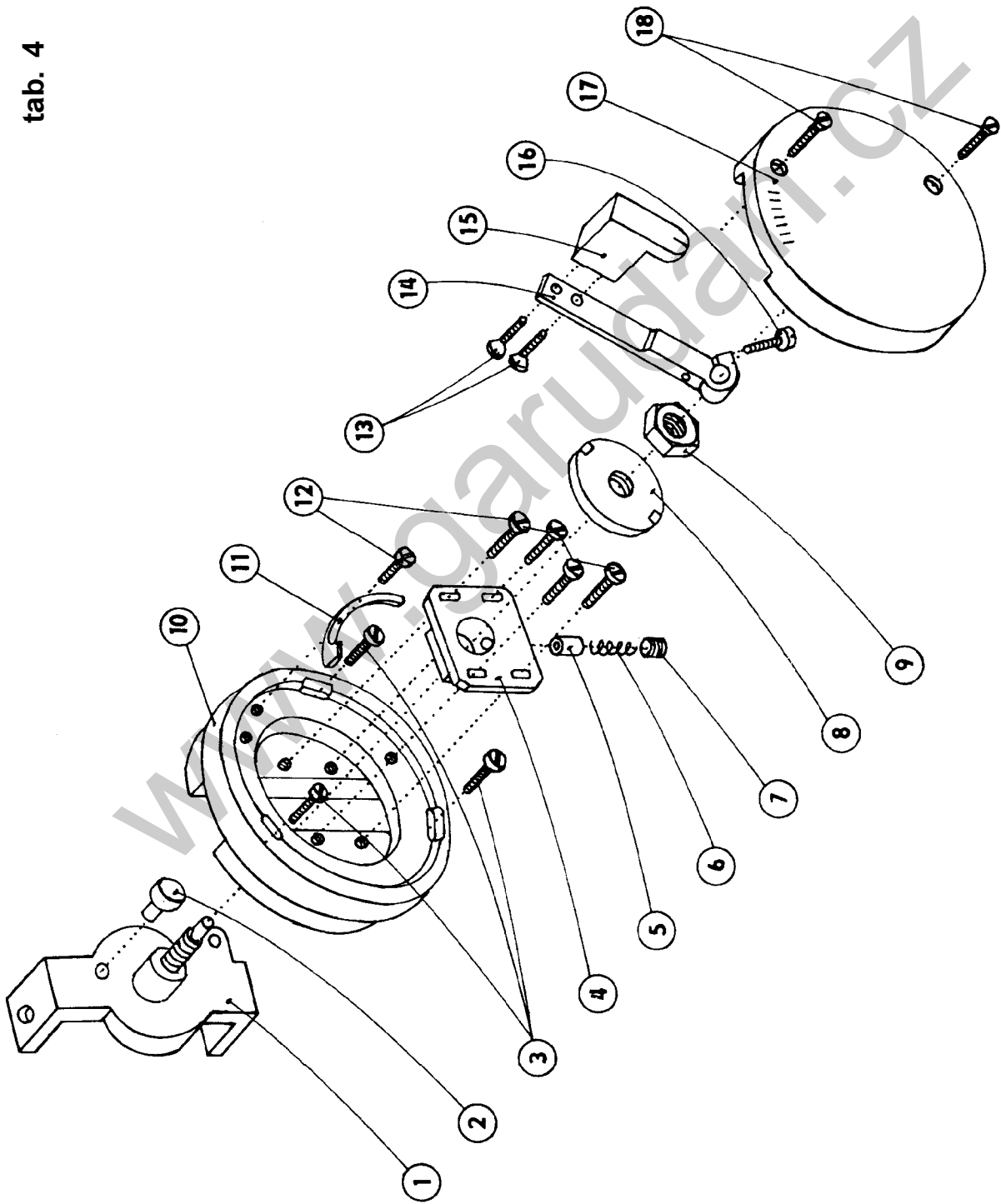

527 - 105

- | | | |
|----|------|--------|
| 1 | S080 | 646027 |
| 2 | S080 | 322247 |
| 3 | S080 | 120276 |
| 4 | S080 | 646120 |
| 5 | S321 | 020000 |
| 6 | S080 | 260139 |
| 7 | S080 | 111099 |
| 8 | S080 | 174066 |
| 9 | S080 | 161236 |
| 10 | S080 | 442530 |
| 11 | S080 | 839010 |
| 12 | S080 | 120219 |
| 13 | S080 | 126101 |
| 14 | S080 | 613472 |
| 15 | S080 | 952251 |
| 16 | S080 | 120543 |
| 17 | S080 | 945048 |
| 18 | S080 | 123130 |

tab. 5

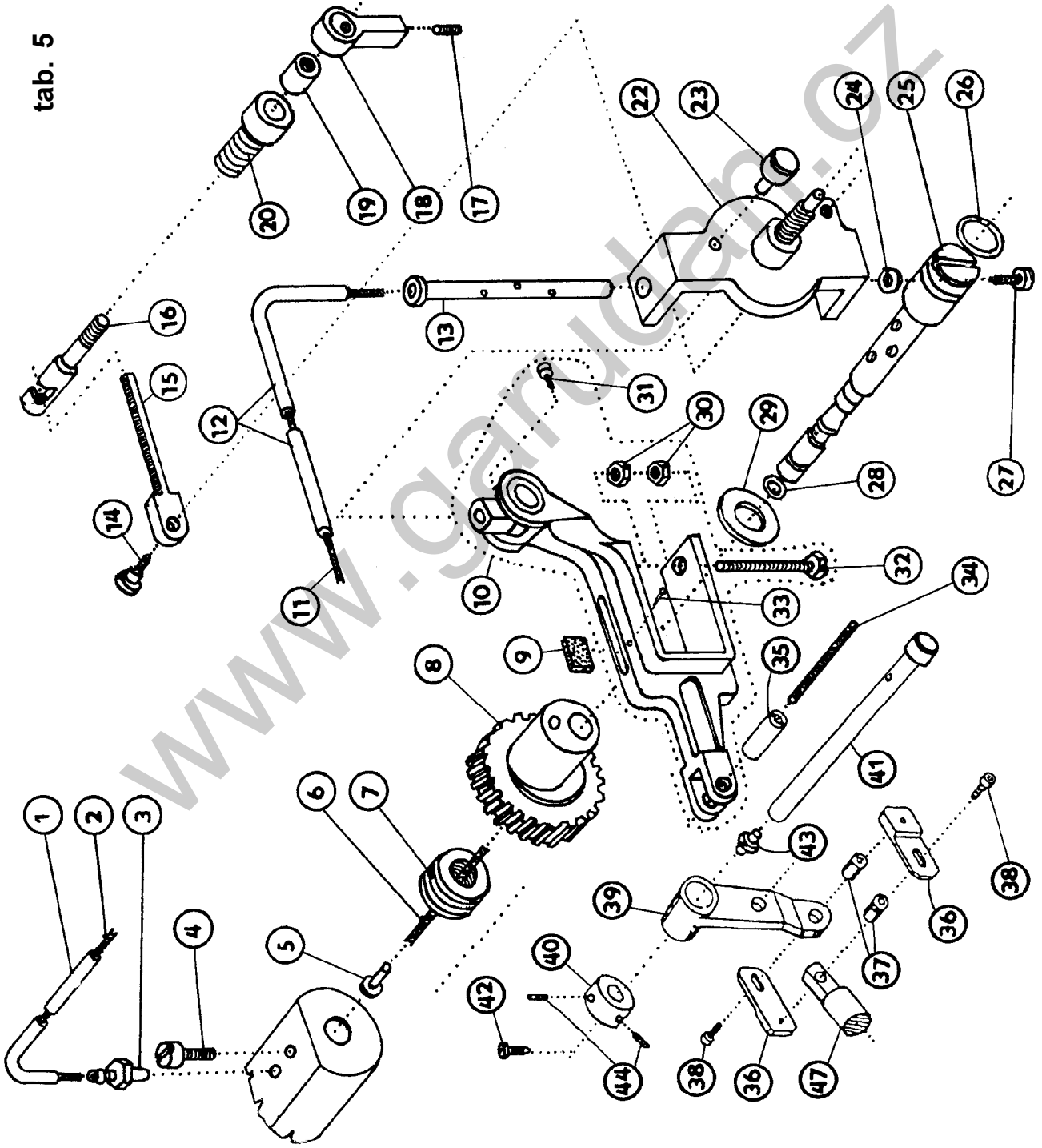

527 - 105

- | | | |
|----|----------------------|--------|
| 1 | S283 | 002005 |
| | f 3,5/f 4,8 x 100 mm | |
| 2 | S708 | 130002 |
| | f 2 x 140 mm | |
| 3 | S080 | 424051 |
| 4 | S080 | 120233 |
| 5 | S080 | 951327 |
| 6 | S708 | 002105 |
| | f 1,5 x 50 mm | |
| 7 | S324 | 010000 |
| 8 | S980 | 035598 |
| 9 | S080 | 945326 |
| 10 | S980 | 024263 |
| 11 | S708 | 130002 |
| | f 2 x 270 mm | |
| 12 | S283 | 002005 |
| | f 3,5/f 4,8 x 210 mm | |
| 13 | S080 | 335101 |
| 14 | S080 | 131391 |
| 15 | S080 | 152099 |
| 16 | S080 | 334097 |
| 17 | S080 | 112101 |
| 18 | S080 | 612342 |
| 19 | S080 | 163093 |
| 20 | S080 | 422184 |
| 22 | S080 | 646027 |
| 23 | S080 | 322247 |
| 24 | S080 | 190359 |
| 25 | S080 | 335105 |
| 26 | S273 | 007000 |
| 27 | S080 | 120221 |
| 28 | S273 | 001001 |
| 29 | S080 | 190526 |
| 30 | S080 | 161233 |
| 31 | S080 | 120291 |
| 32 | S080 | 141223 |
| 33 | S738 | 002000 |
| 34 | S708 | 130002 |
| | f 2 x 150 mm | |
| 35 | S080 | 318210 |
| 36 | S080 | 648132 |
| 37 | S080 | 410595 |
| 38 | S080 | 120589 |
| 39 | S080 | 613519 |
| 40 | S080 | 436000 |
| 41 | S080 | 320289 |
| 42 | S080 | 132203 |
| 43 | S425 | 041000 |
| 44 | S080 | 112013 |
| 47 | S980 | 021353 |

tab. 6

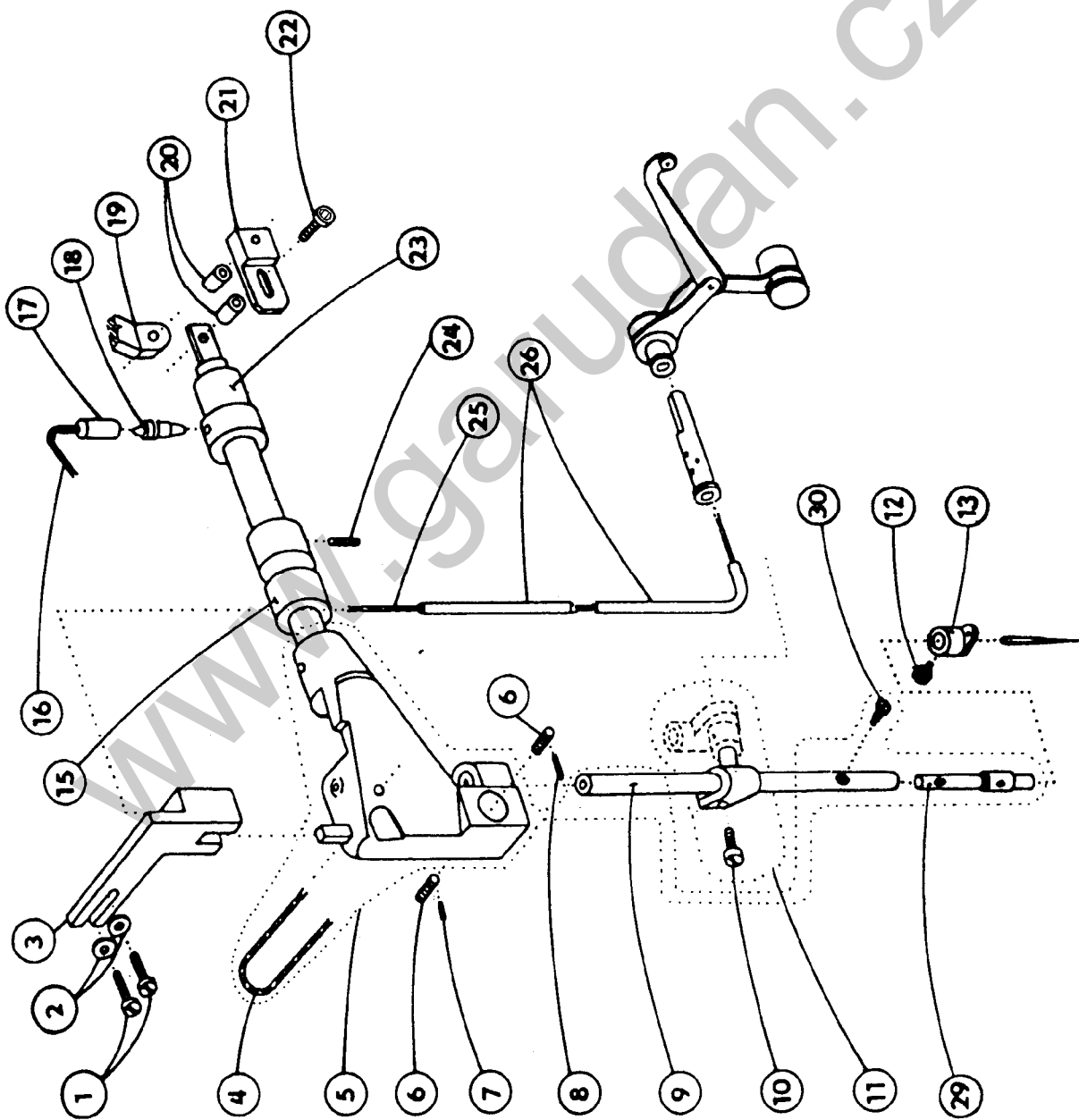

527 - 105

1	S080 120276
2	S080 190353
3	S080 646104
4	S708 002105 ř 1,5 x 80 mm
5	S980 021338
6	S080 113115
7	S080 111229
8	S080 111248
9	S080 391155
10	S080 124050
11	S980 035499
12	S080 135029
13	S080 627170
15	S080 413311
16	S708 002105 ř 1,5x 250 mm
17	S283 002005 ř 3,5/ř 4,8 x 190 mm
18	S080 424051
19	S080 613519
20	S080 410595
21	S080 648132
22	S080 120589
23	S080 421341
24	S080 111222
25	S708 002105 ř 1,5 x 150 mm
26	S283 002005 ř 3,5/ř 4,8 x 70 mm
29	S080 394167
30	S080 136082

527 - 105

1	S080	945317
2	S080	120543
3	S080	623249
4	S080	326213
5	S080	283152
6	S080	113122
7	S080	113123
8	S311	732060
9	S311	732040
10	S080	839215
12	S080	136023
13	S080	615021
14	S080	421330
15	S080	112014
17	S080	120239
18	S080	190554
19	S080	271393
20	S980	060209
21	S080	264288
22	S080	120221
23	S080	633196
24	S080	190346
25	S080	271337
26	S080	382101
27	S080	814014
28	S080	120217
29	S080	436331
30	S080	120050
31	S080	392105
32	S080	161139
33	S080	161333

tab. 7

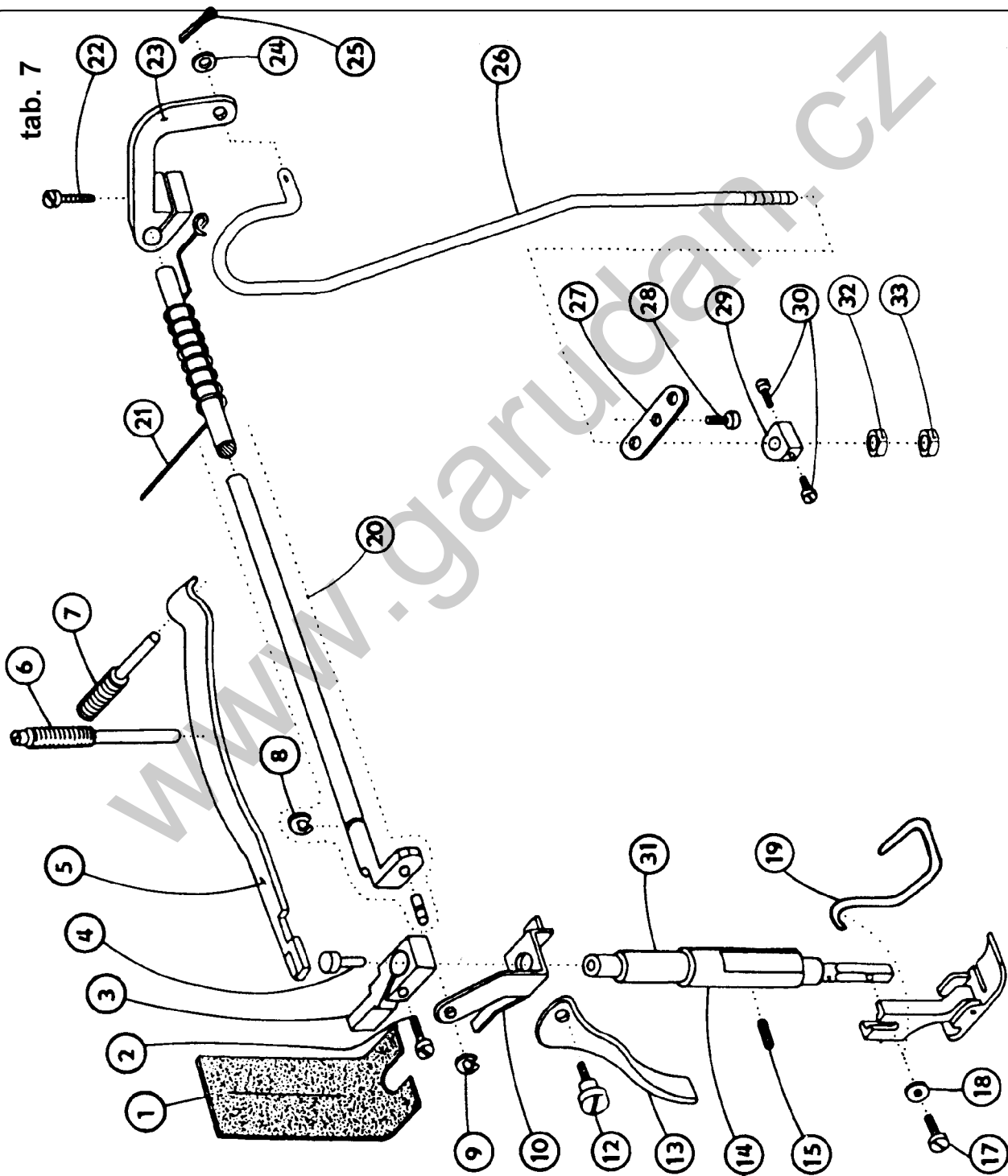

tab. 8

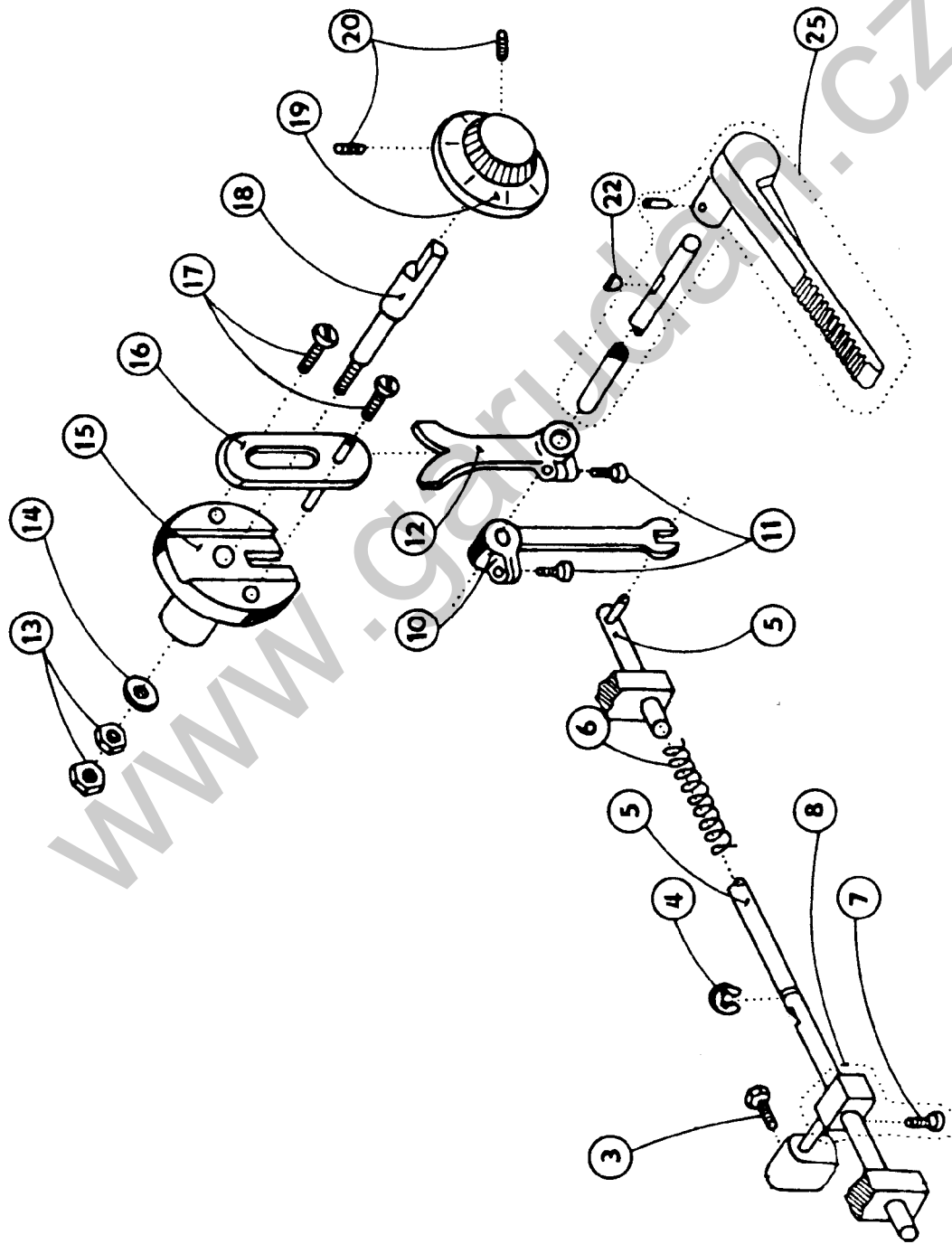

527 - 105

3	S080	141102
4	S311	732070
5	S980	043301
6	S080	260547
7	S080	120227
8	S980	022126
10	S080	613373
11	S080	120221
12	S080	613328
13	S080	161142
14	S080	192061
15	S080	441187
16	S980	049785
17	S080	120246
18	S080	342258
19	S980	233031
20	S080	112013
22	S311	728537
25	S980	044714

tab. 9

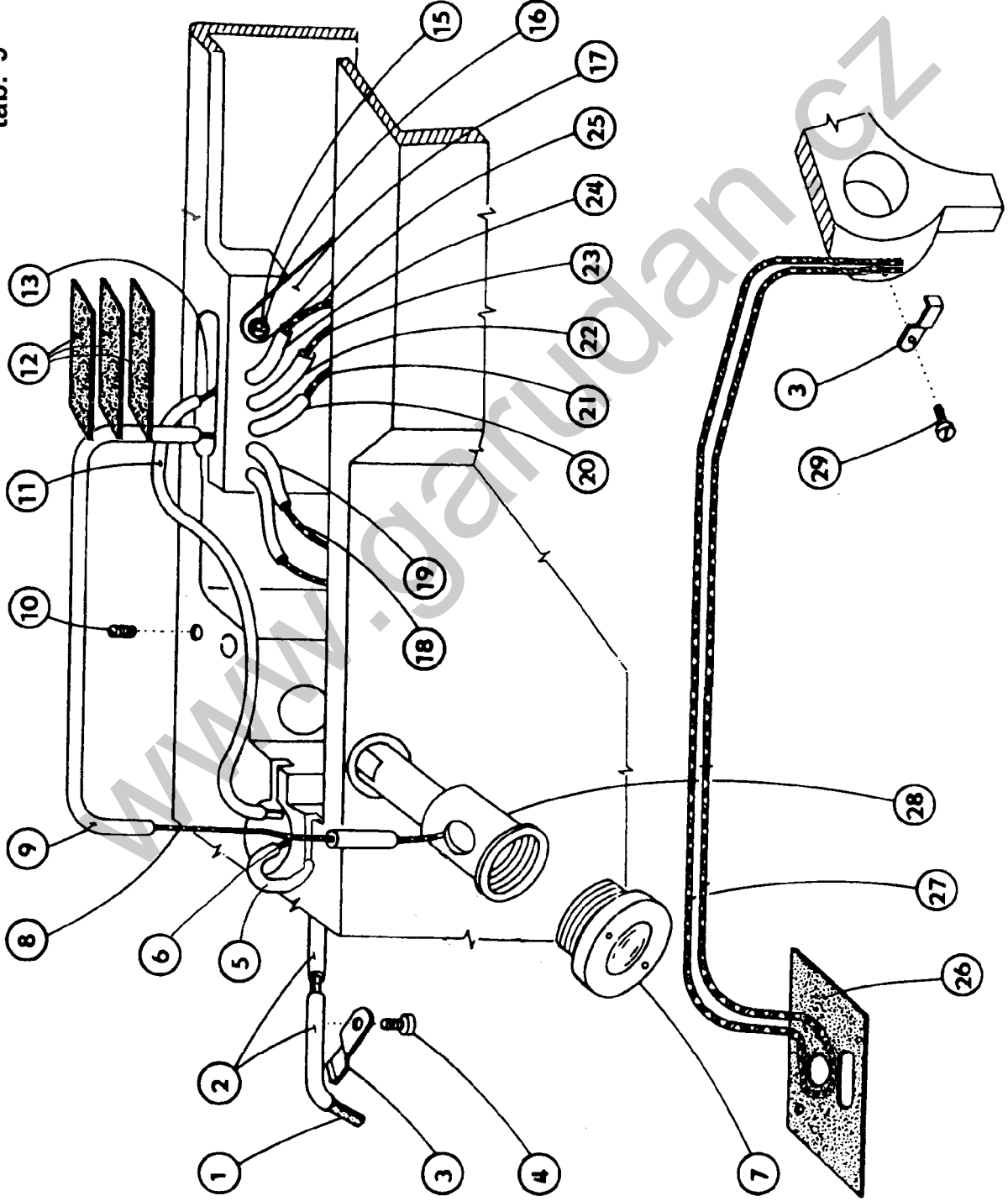

527 - 105

1	S080	945180
2	S283	002001
3	S080	824095
4	S080	120245
5	S283	002001
6	S708	130002
7	S321	001000
8	S708	002105
9	S283	002005
10	S080	111245
11	S283	002005
12	S080	945316
13	S708	002105
15	S080	120259
16	S080	190359
17	S980	041176
18	S708	130002
19	S283	002005
20	S283	002005
21	S708	130002
22	S283	002005
23	S708	130002
24	S283	002005
25	S708	130002
26	S080	945286
27	S708	130004
28	S080	441313
29	S080	120216

tab. 10

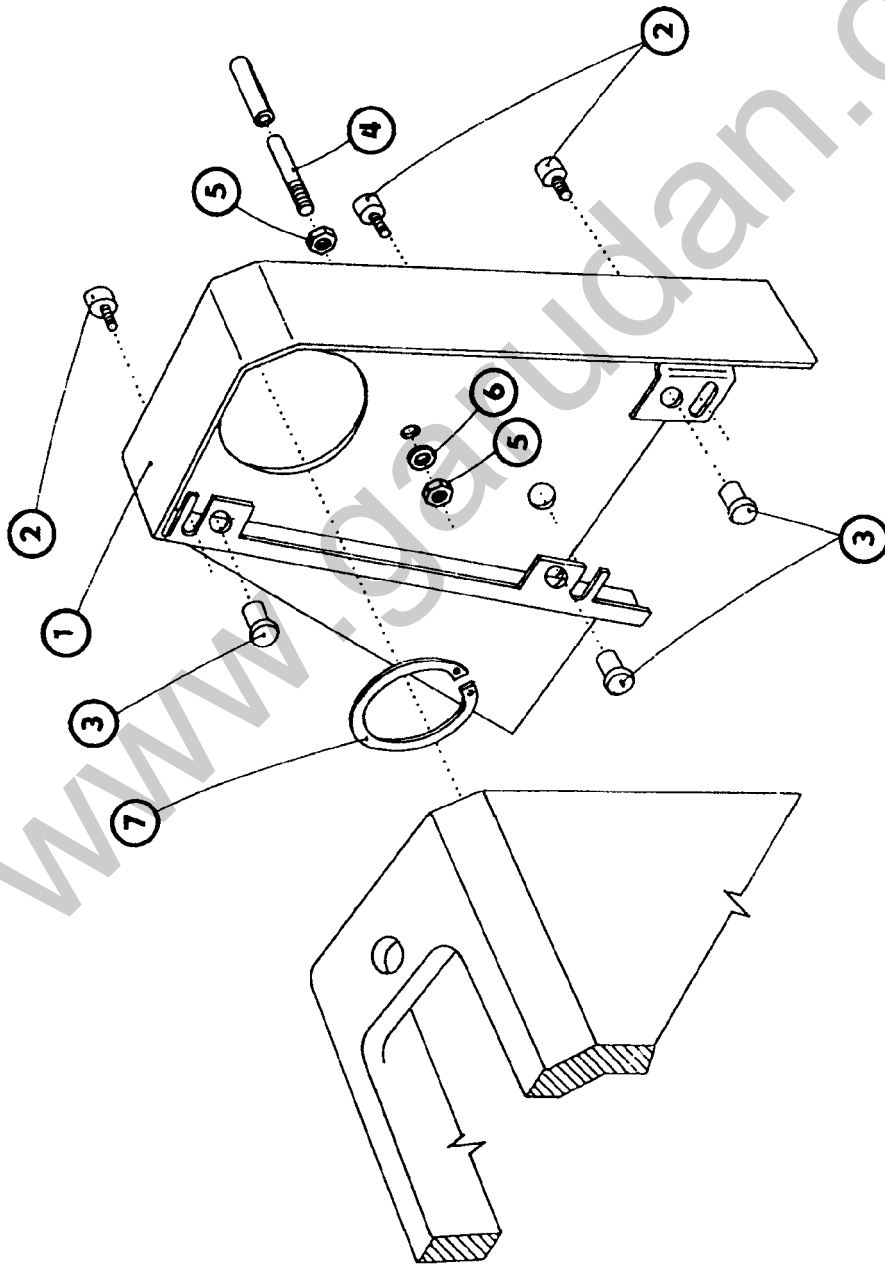

527 - 105

- | | | |
|---|------|--------|
| 1 | S980 | 041162 |
| 2 | S080 | 120346 |
| 3 | S273 | 005001 |
| 4 | S080 | 316096 |
| 5 | S080 | 161151 |
| 6 | S080 | 191112 |
| 7 | S311 | 733620 |

tab. 11

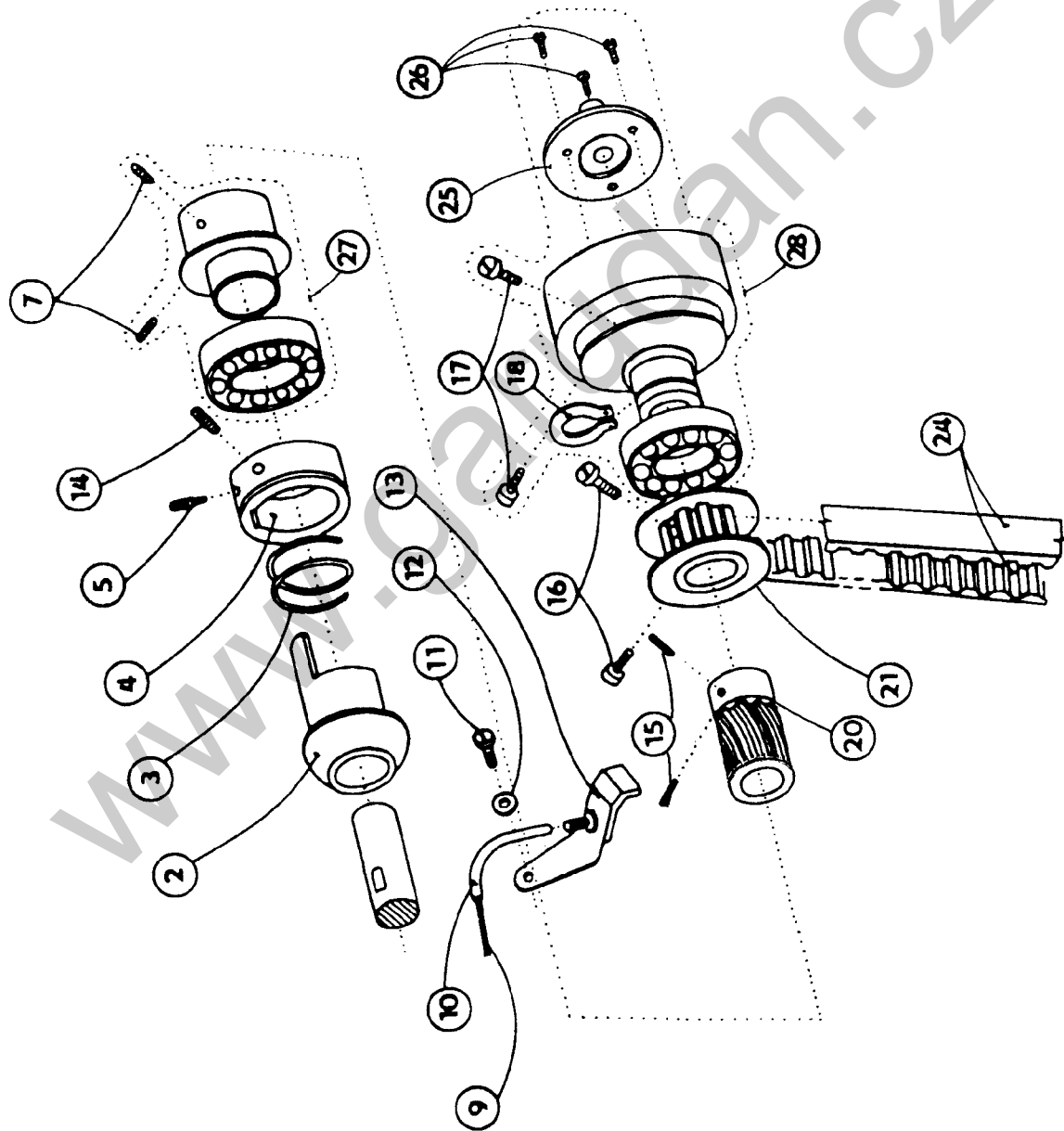

527 - 105

2	S080	441541
3	S080	260467
4	S080	436338
5	S080	113115
7	S080	111225
9	S708	130002
		ř 2 x 130 mm
10	S283	002001
		ř 3,5/ř 4,8 x 90 mm
11	S080	120259
12	S080	190359
13	S980	041176
14	S080	112013
15	S080	111343
16	S080	122029
17	S080	120006
18	S311	733300
20	S980	045330
21	S980	045315
24	S272	011015
25	S080	442548
26	S080	120252
27	S980	035849
28	S980	045301

tab. 12

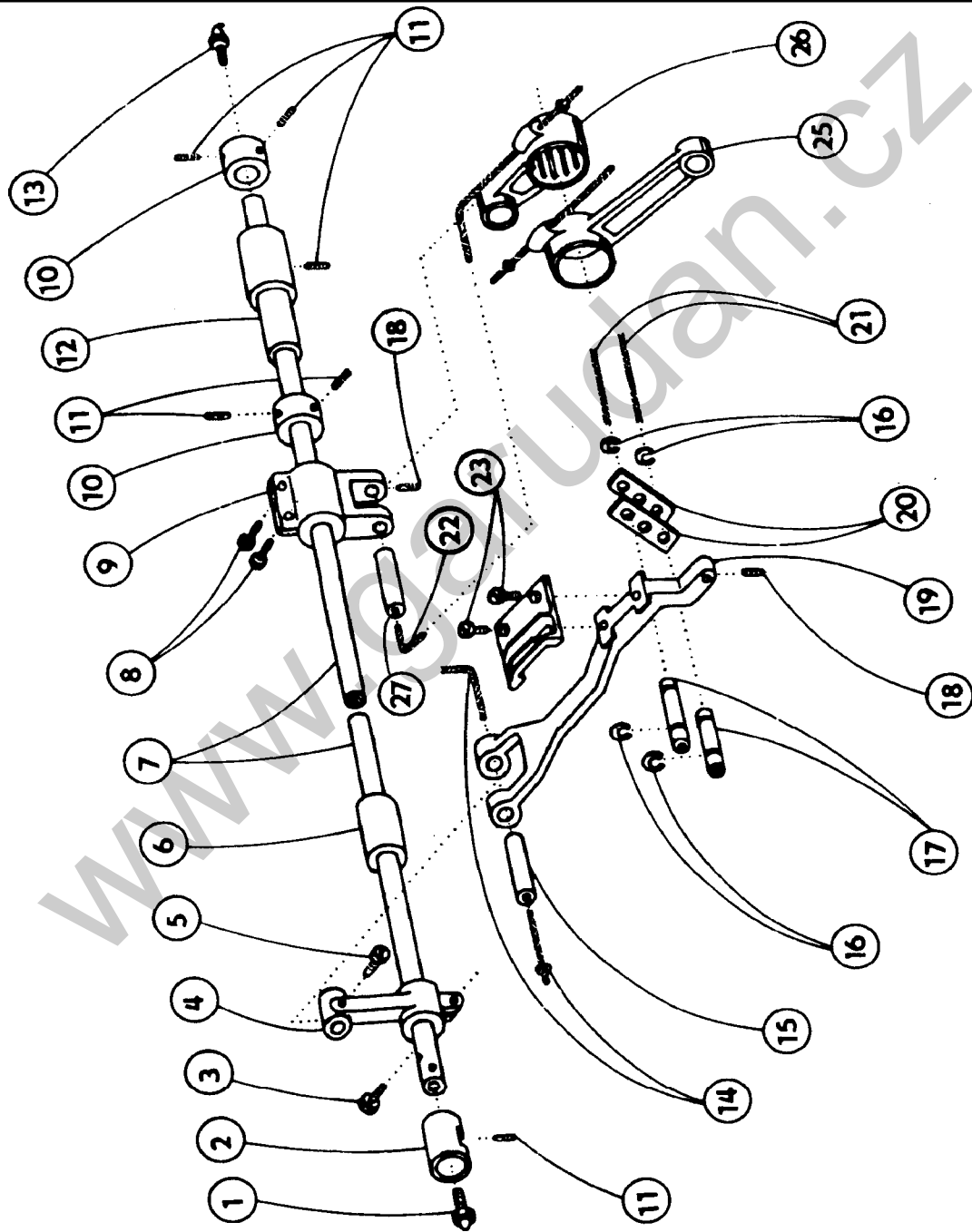

527 - 105

1	S425	041000
2	S080	413252
3	S080	141133
4	S080	613495
5	S080	124050
6	S080	410532
7	S080	345067
8	S080	120229
9	S080	613216
10	S080	436000
11	S080	112013
12	S080	412193
13	S425	061000
14	S708	002105
15		ř 1,5 x 160 mm
16	S080	338069
17	S311	732050
18	S080	318144
19	S080	111227
20	S080	622092
21	S080	612109
22	S708	002105
23		ř 1,5 x 60 mm
25	S080	630248
26	S980	044045
27	S080	344035

tab. 13

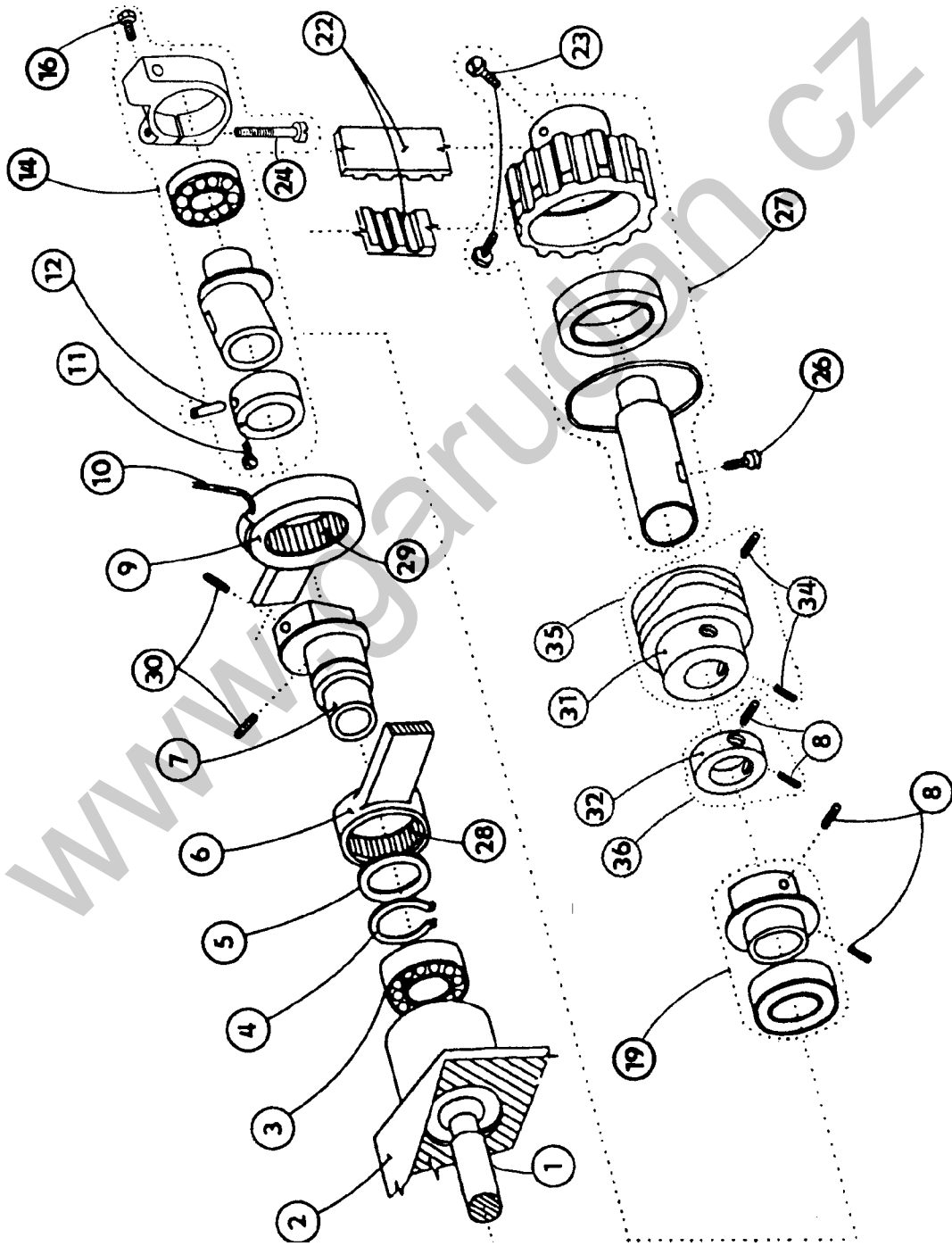

527 - 105

1	S080	342243
2	S080	724134
3	S324	020093
4	S311	733180
5	S080	814338
6	S080	630248
7	S080	671152
8	S080	112013
9	S980	044045
10	S708	002105
11	ř 1,5 x 350 mm	
12	S080	141088
14	S980	035422
16	S080	141102
19	S980	035420
22	S272	011015
23	S080	122029
24	S080	120222
26	S080	122031
27	S980	045231
28	S324	510900
29	S324	512900
30	S080	111343
31	S080	672166
32	S080	436346
34	S080	120468
35	S980	035570
36	S980	035441

tab. 14

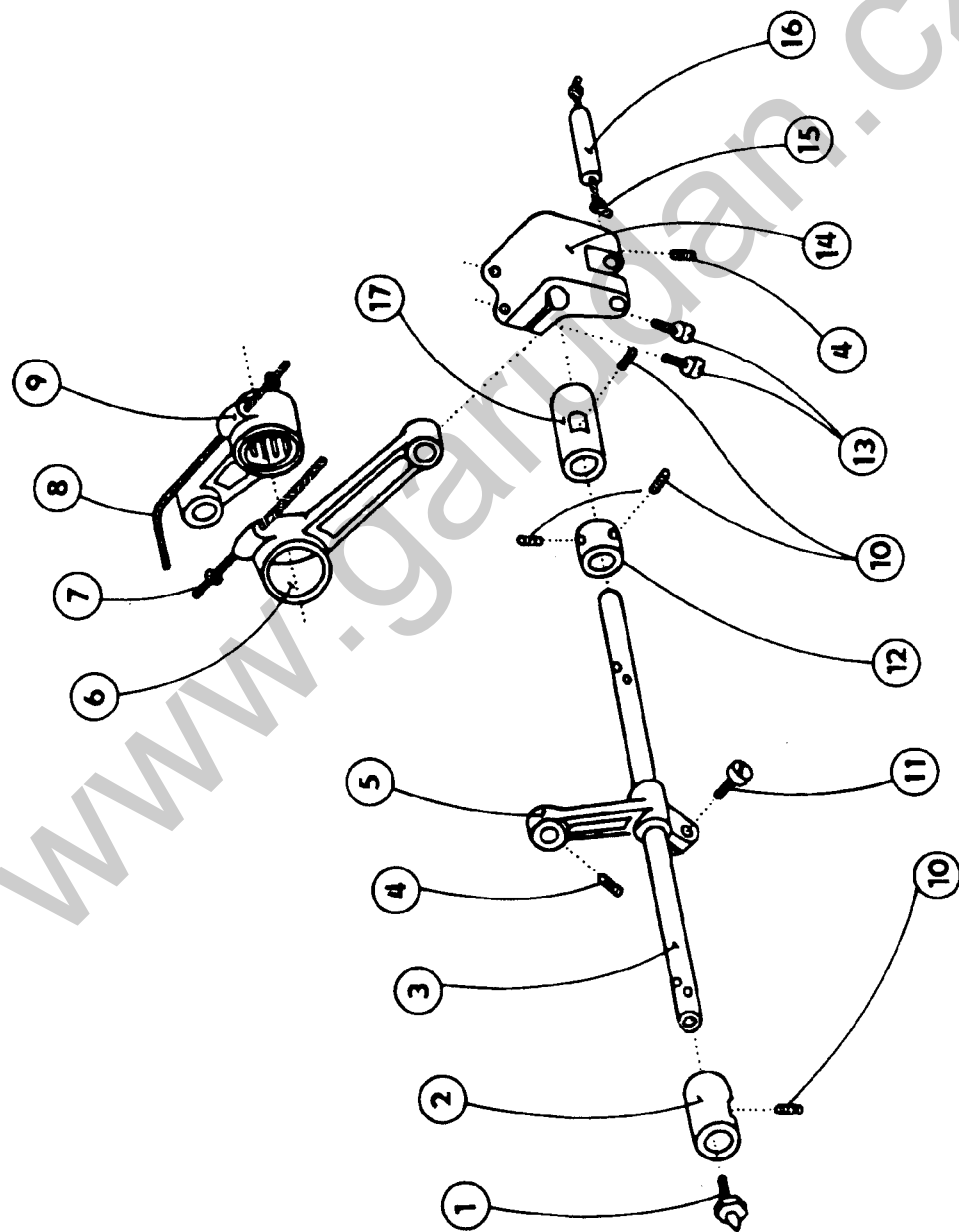

527 - 105

- | | | |
|----|------|--------------|
| 1 | S425 | 041000 |
| 2 | S080 | 413251 |
| 3 | S080 | 345065 |
| 4 | S080 | 111227 |
| 5 | S080 | 613195 |
| 6 | S080 | 630248 |
| 7 | S708 | 002105 |
| | ř | 1,5 x 220 mm |
| 8 | S708 | 002105 |
| | ř | 1,5 x 350 mm |
| 9 | S980 | 044045 |
| 10 | S080 | 112013 |
| 11 | S080 | 120229 |
| 12 | S080 | 436000 |
| 13 | S080 | 120231 |
| 14 | S080 | 613152 |
| 15 | S708 | 130002 |
| | ř | 2 x 60 mm |
| 16 | S080 | 344035 |
| 17 | S080 | 410538 |

tab. 15

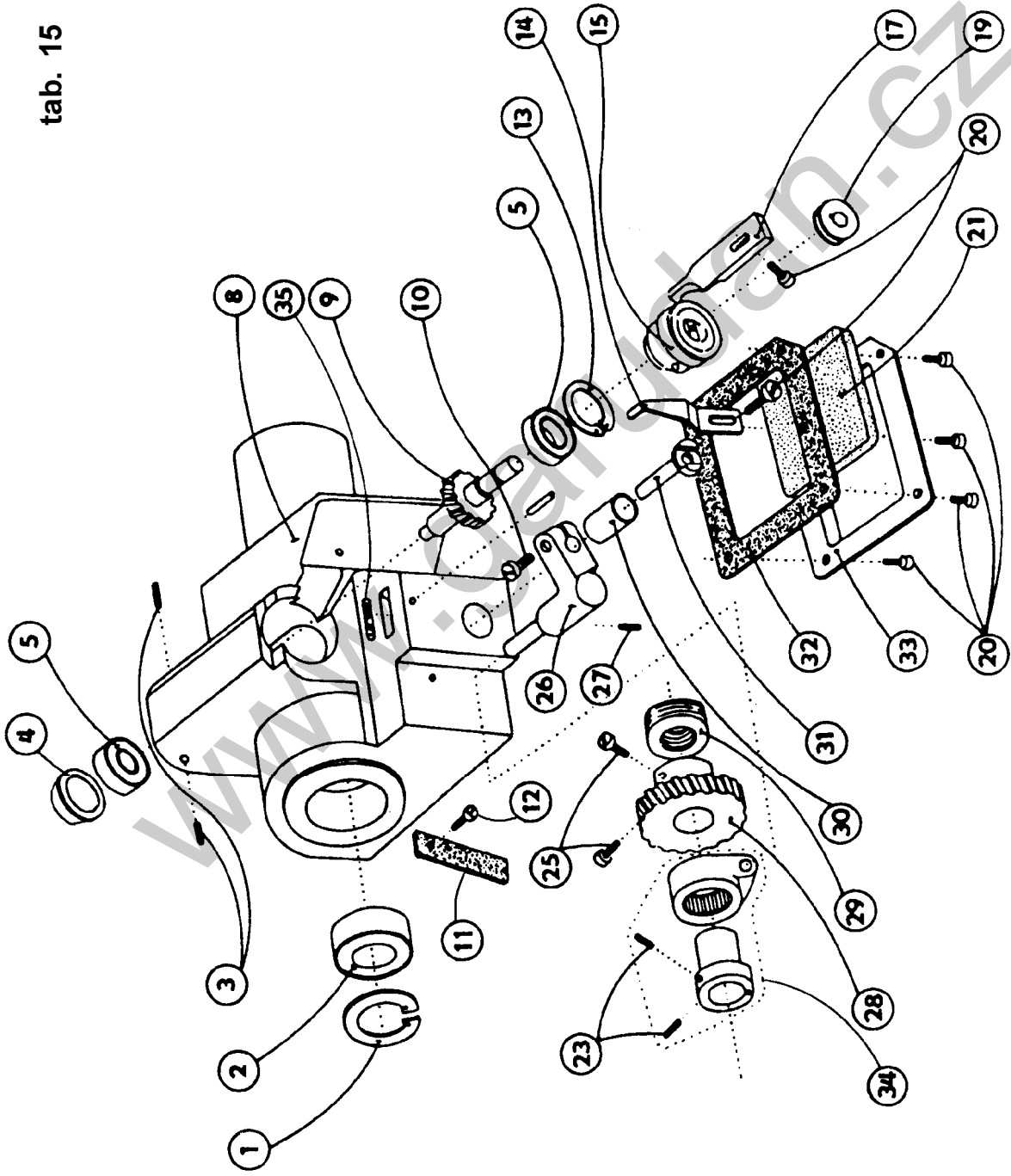

527 - 105

1	S311	733261
2	S324	920796
3	S080	111219
4	S080	441287
5	S324	910093
8	S080	724134
9	S080	552168
10	S080	120226
11	S080	945283
12	S080	120601
13	S311	733221
14	S080	825740
15	S980	008251
17	S080	825744
19	S080	685051
20	S080	120246
21	S080	945285
23	S080	111343
25	S080	122007
26	S080	613466
27	S080	111094
28	S080	552167
29	S324	010000
30	S080	410530
31	S080	323155
32	S080	990134
33	S080	827179
34	S980	035406
35	S708	130002

f 2 x 40 mm

tab. 16

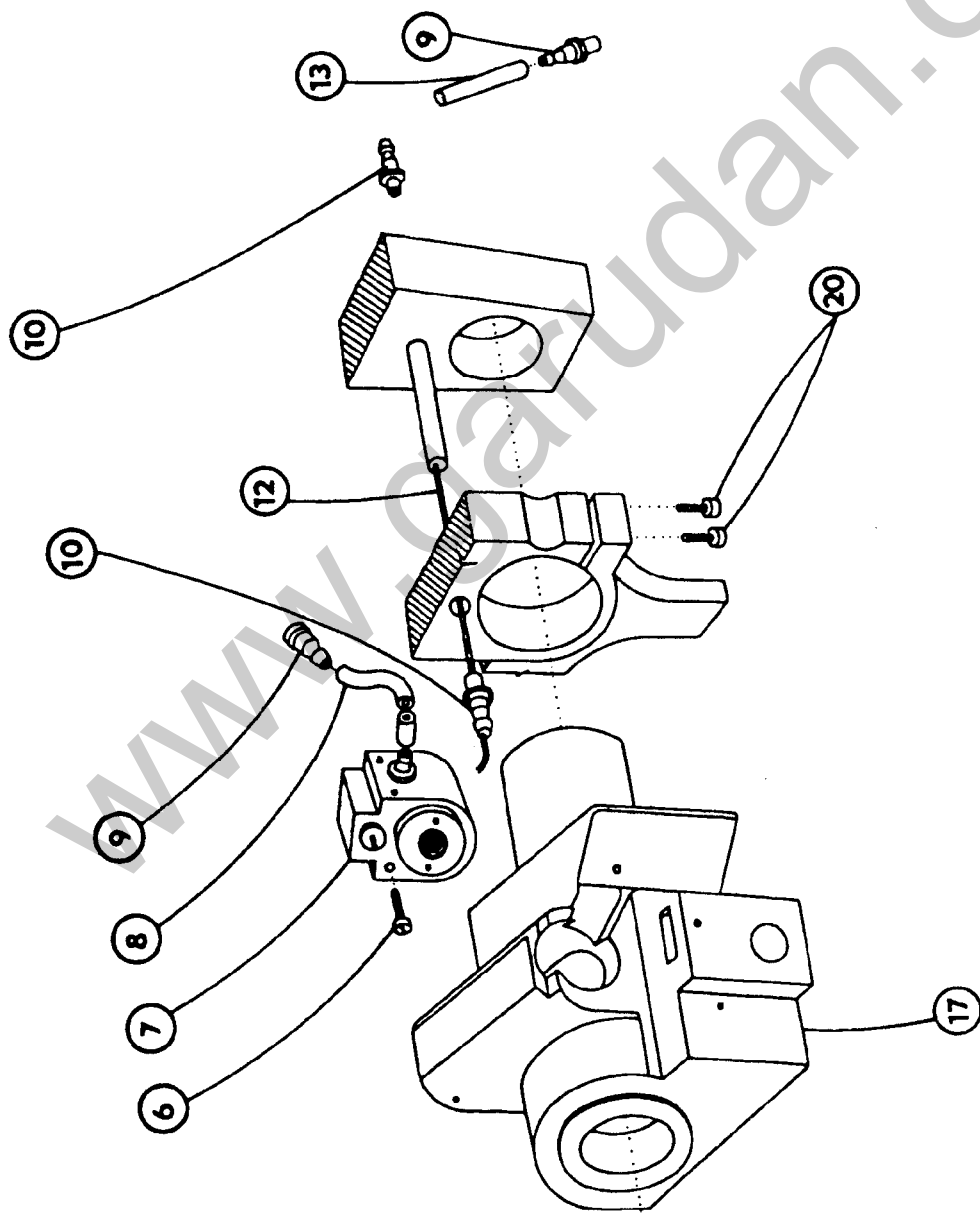

527 - 105

6	S080	120269
7	S980	035527
8	S283	002001
		ř 3,5/ř 4,8 x 100 mm
9	S080	424051
10	S080	424060
12	S708	130005
		ř 5 x 300 mm
13	S283	002005
		ř 3,5/ř 4,8 x 170 mm
17	S080	724134
20	S080	120425

tab. 17

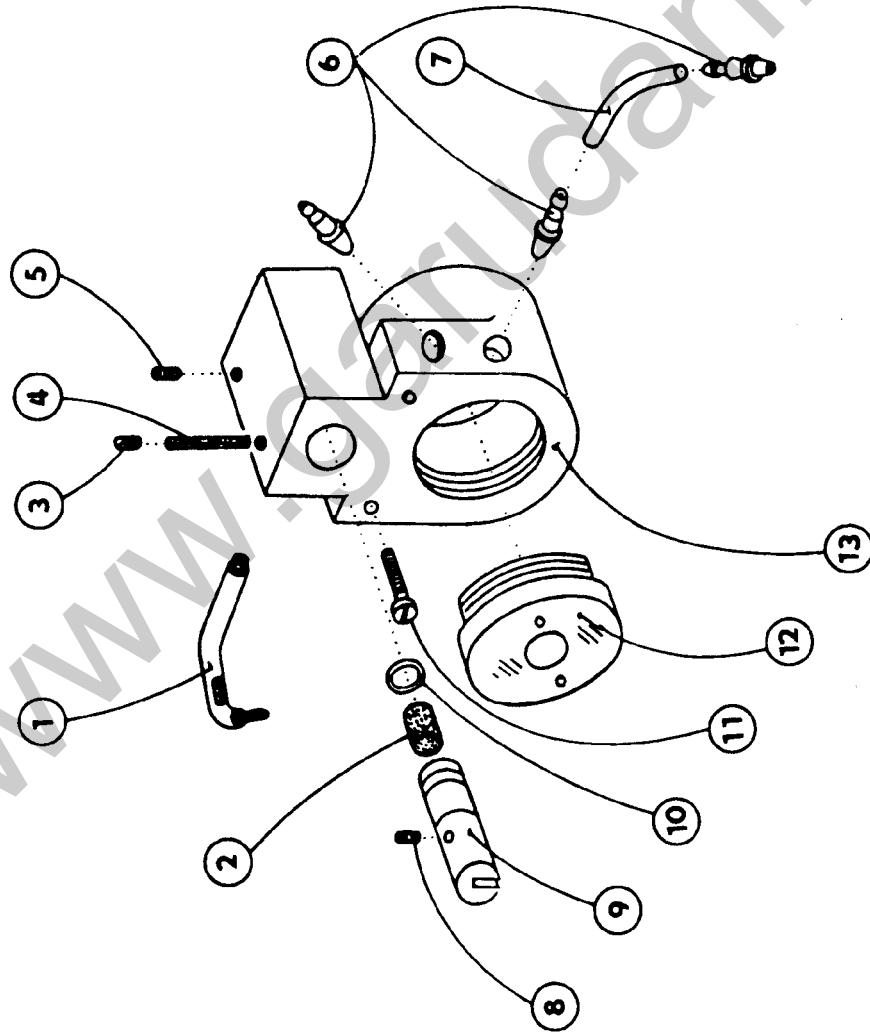

527 - 105

- | | | |
|----|----------------------|--------|
| 1 | S980 | 035526 |
| 2 | S080 | 945077 |
| 3 | S080 | 111252 |
| 4 | S080 | 945185 |
| 5 | S080 | 111233 |
| 6 | S080 | 424051 |
| 7 | S283 | 002005 |
| | r 3,5/f 4,8 x 100 mm | |
| 8 | S080 | 945170 |
| 9 | S080 | 346053 |
| 10 | S273 | 001001 |
| 11 | S080 | 120269 |
| 12 | S321 | 001002 |
| 13 | S080 | 725023 |

tab. 18

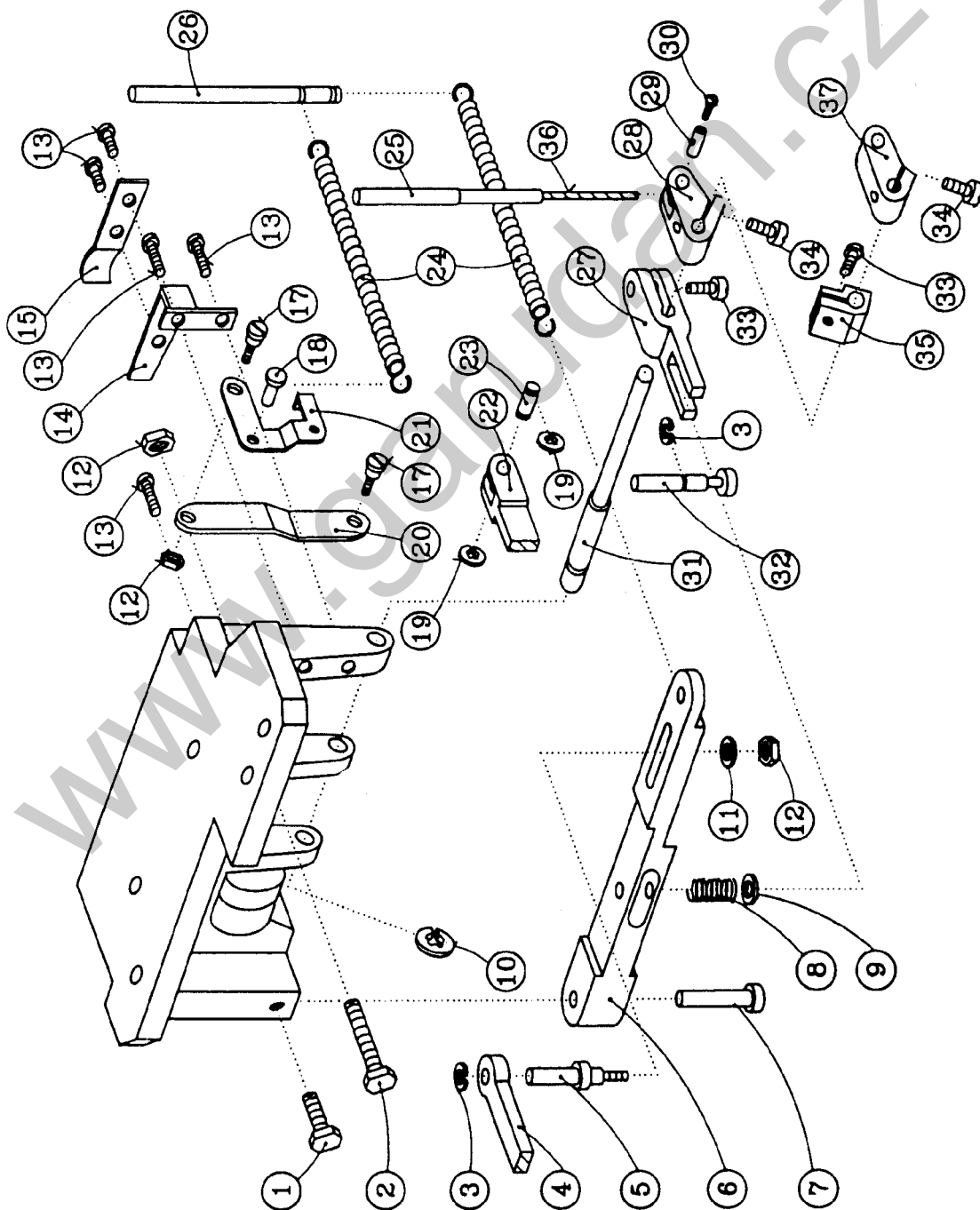

527 - 105

1	S080	141142
2	S080	141204
3	S311	732040
4	S080	632147
5	S080	333121
6	S080	646145
7	S080	320257
8	S080	260434
9	S080	190359
10	S311	732050
11	S080	190353
12	S080	161144
13	S080	120218
14	S080	825856
15	S080	825586
17	S080	131378
18	S080	320258
19	S080	274104
20	S080	822446
21	S080	822409
22	S080	630272
23	S080	314167
24	S080	263103
25	S080	278009
26	S080	310364
27	S080	625132
28	S080	613482
29	S080	334090
30	S080	120246
31	S080	341202
32	S080	322231
33	S080	120220
34	S080	120221
35	S080	627142
36	S080	049786
37	S080	613420

tab. 19

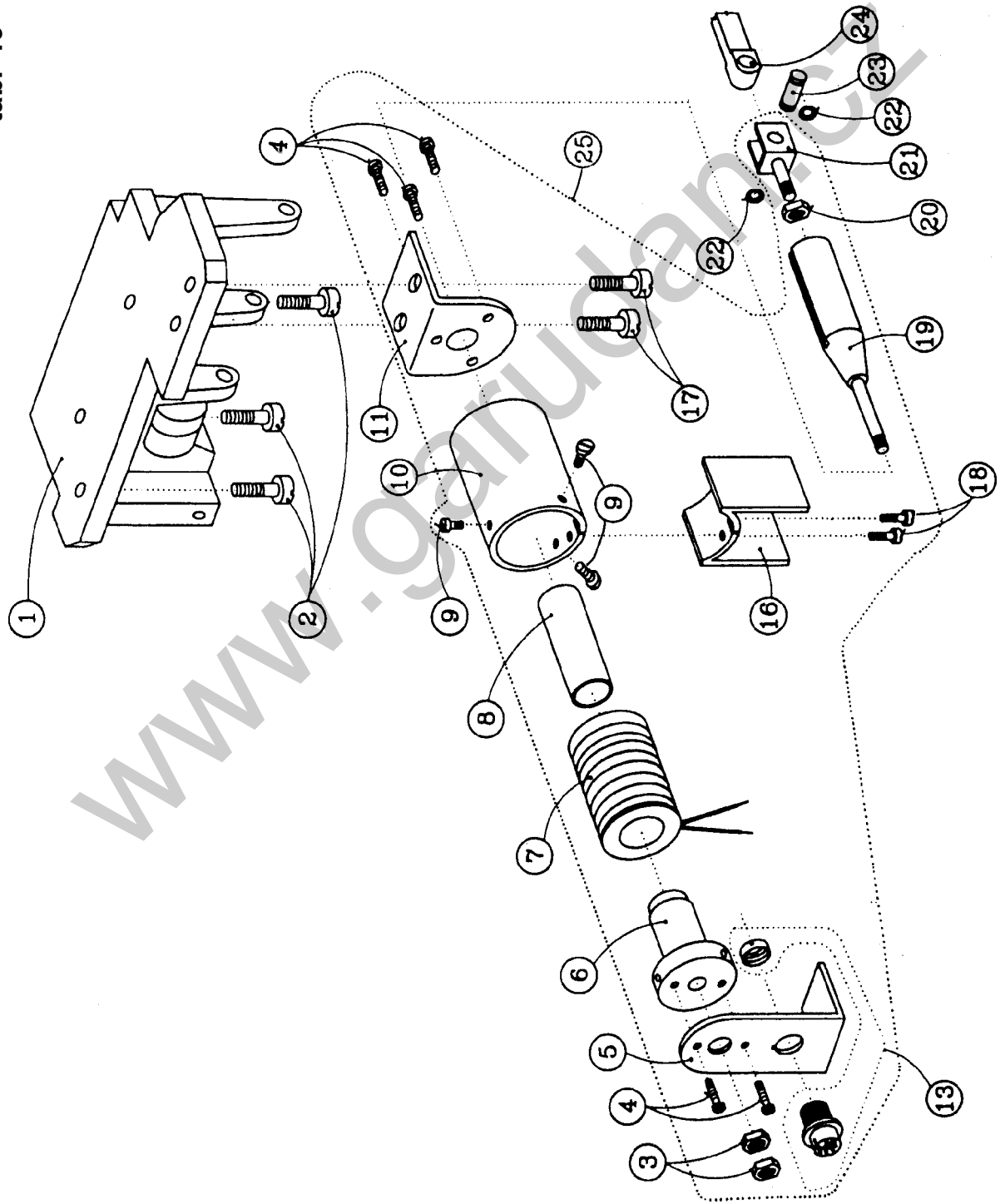

527 - 105

1	S080	744380
2	S080	120322
3	S080	161165
4	S080	126078
5	S080	825591
6	S080	422155
7	S980	091220
8	S323	914064
9	S080	120252
10	S080	422154
11	S080	825590
13	S374	059099
16	S080	952235
17	S080	120220
18	S080	120245
19	S980	091219
20	S080	161143
21	S080	154033
22	S080	274104
23	S080	314167
24	S080	630272
25	S980	091446

tab. 20

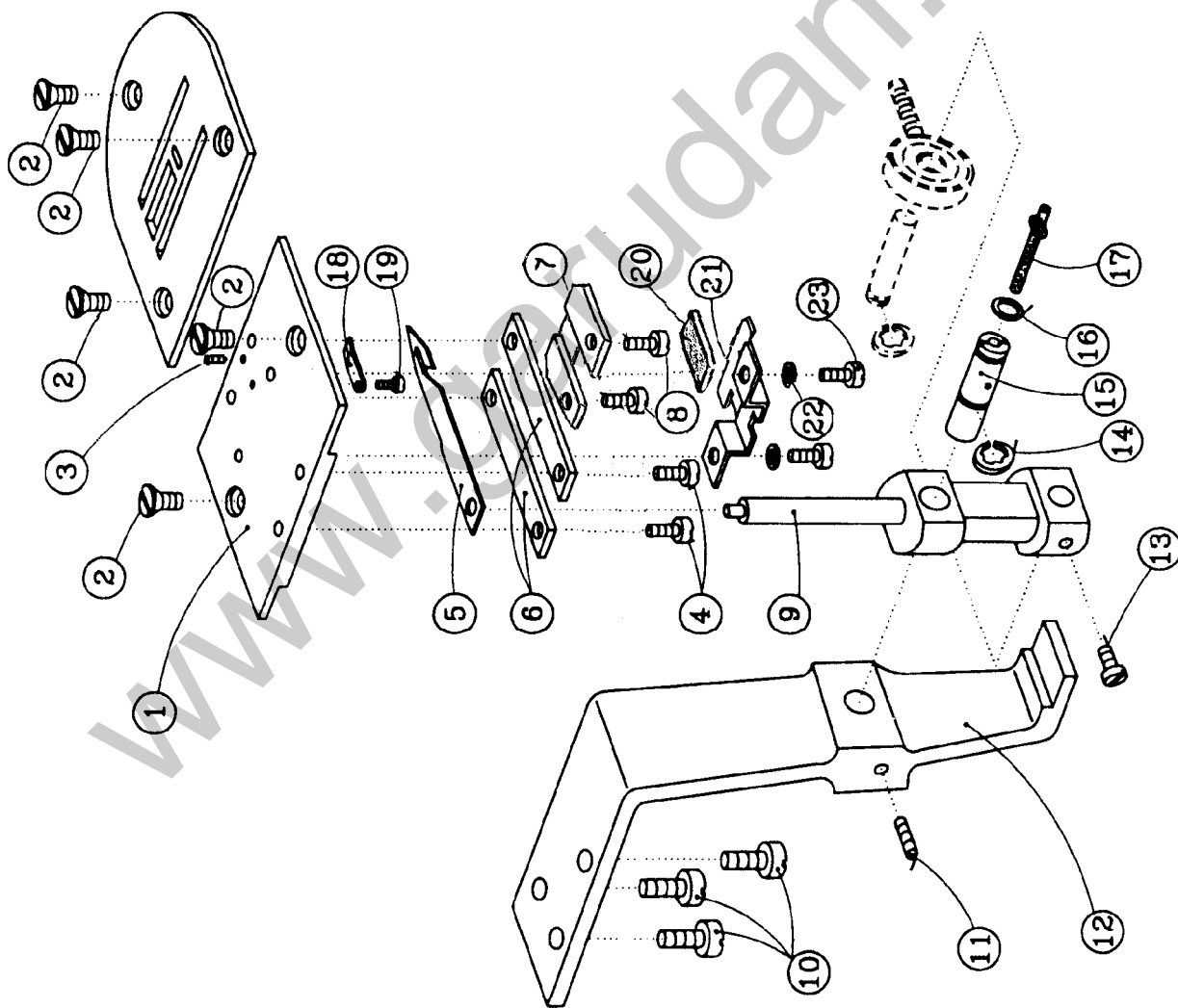

523 - 105

1	S080	647222
2	S080	123117
3	S080	111328
4	S080	120332
5	S080	870167
6	S080	825868
7	S080	826039
8	S080	132112
9	S080	635171
10	S080	120293
11	S080	111244
12	S080	765090
13	S080	120218
14	S080	274093
15	S080	338190
16	S080	190483
17	S708	130003
		ø 3 x 80mm
18	S080	870140
19	S080	132216
20	S080	945315
21	S080	839058
22	S080	191118
23	S080	120215

tab. 21

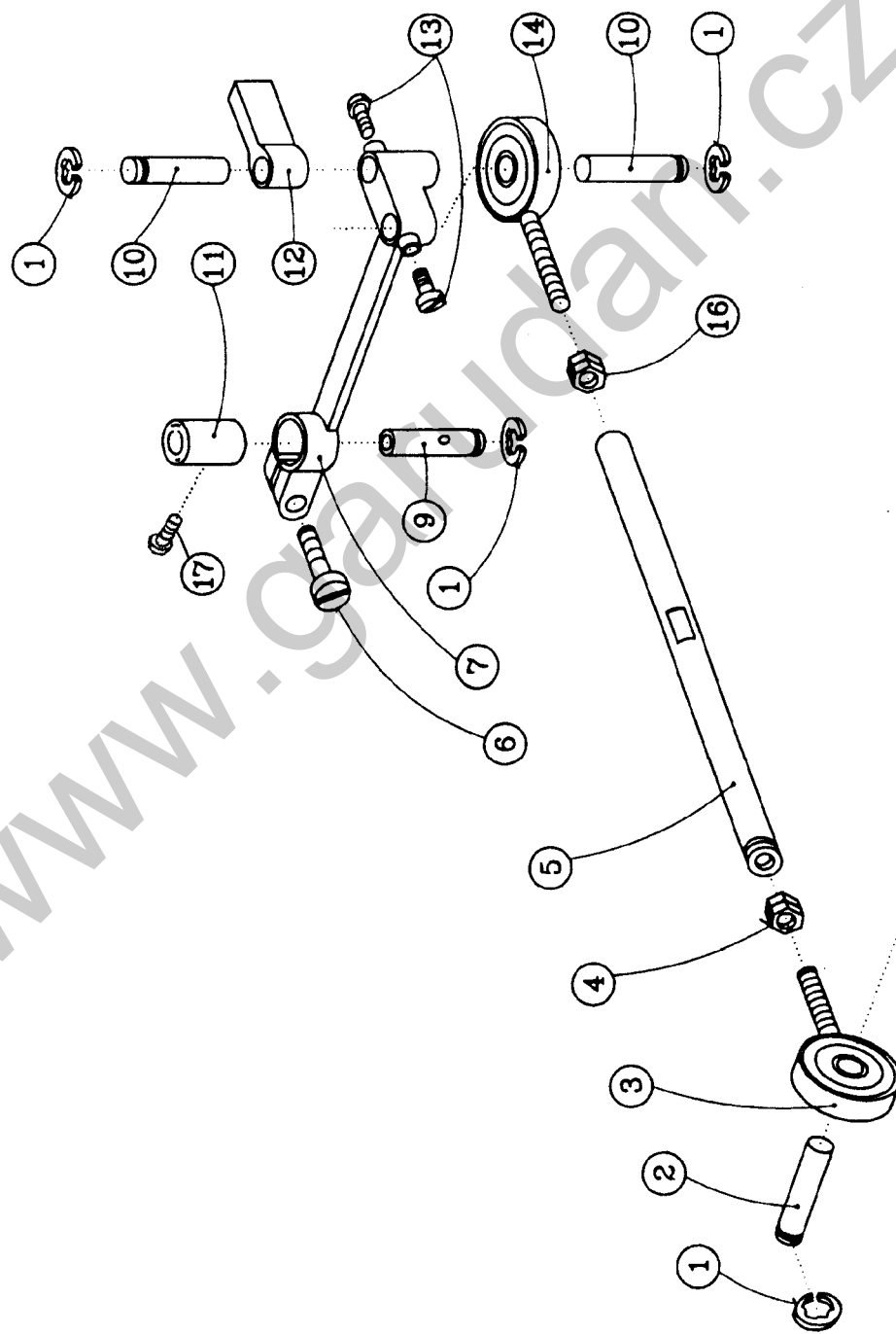

527 - 105

1	S311	732040
2	S080	314165
3	S980	049811
4	S080	161227
5	S080	334093
6	S080	120229
7	S080	636243
9	S080	318171
10	S080	314166
11	S080	410481
12	S080	632147
13	S080	120218
14	S980	049810
16	S080	161144
17	S080	132183

527 - 105

1	S273	025410
2	S080	441560
3	S080	190593
4	S080	264281
5	S980	035654
6	S080	310377
7	S080	441308
8	S080	613468
9	S080	343074
10	S080	265037
11	S321	953200
12	S080	112115
13	S080	945296
14	S080	111094
15	S080	672174
16	S311	732040
17	S080	124050
18	S080	111230
19	S080	260483
20	S080	870170
21	S980	025248
22	S980	025249
23	S080	827194
24	S080	260510
25	S080	163106
26	S080	161138
27	S311	515091
28	S980	036122

tab. 22

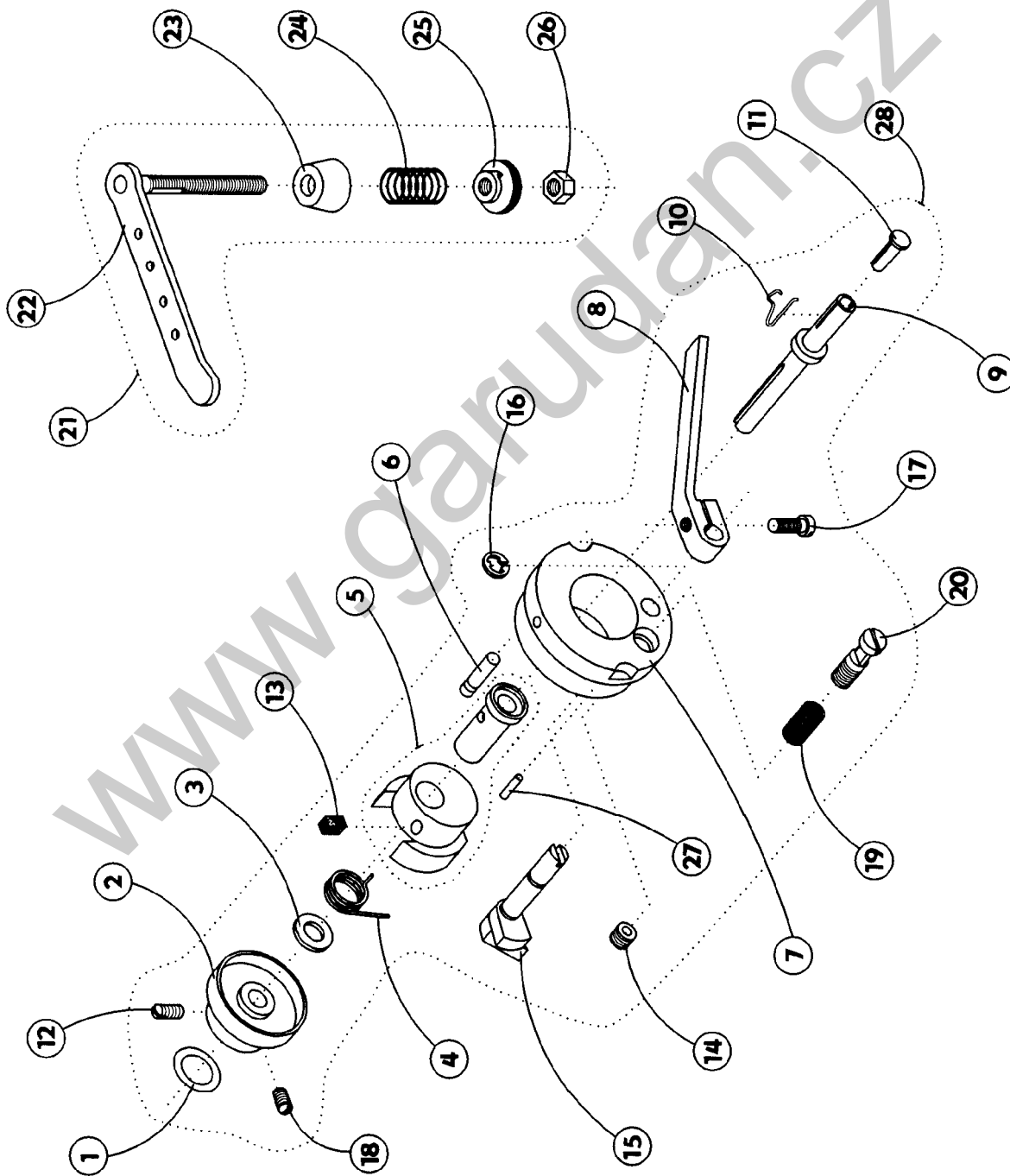

527 - 105

S980 008251

- 1 S080 690029
- 2 S080 683063
- 3 S980 081122
- 4 S080 683053
- 5 S080 683064
- 6 S980 081138
- 7 S080 683067
- 8 S980 081139
- 9 S080 685051
- 10 S080 683083
- 11 S080 681029

tab. 23

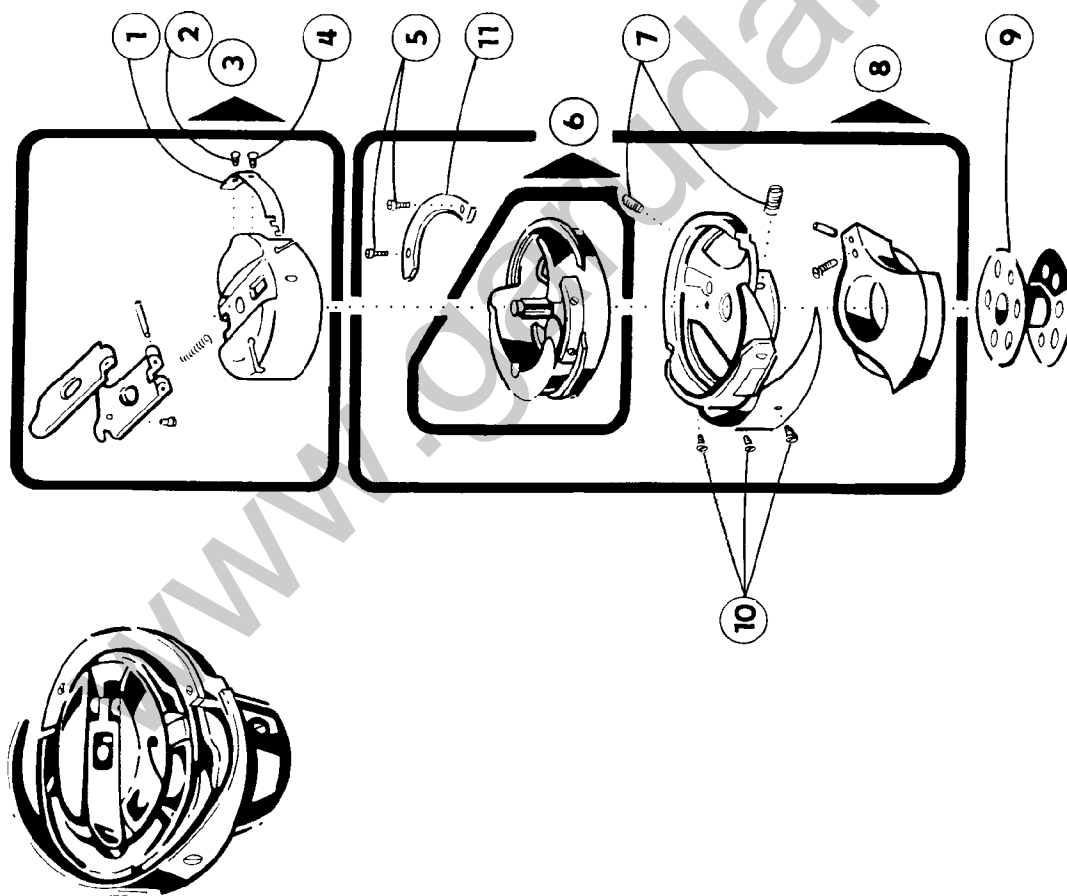

527 - 105

S980 099038/1

- 1 S273 940127
- 2 S615 932046
- 3 S273 940141
- 4 S321 953251
- 5 S080 725050
- 6 S080 826387
- 7 S080 941091
- 8 S314 016020
- 9 S080 225031
- 10 S413 100130
- 11 OAPP 000301
- 12 S321 026000

tab. 24

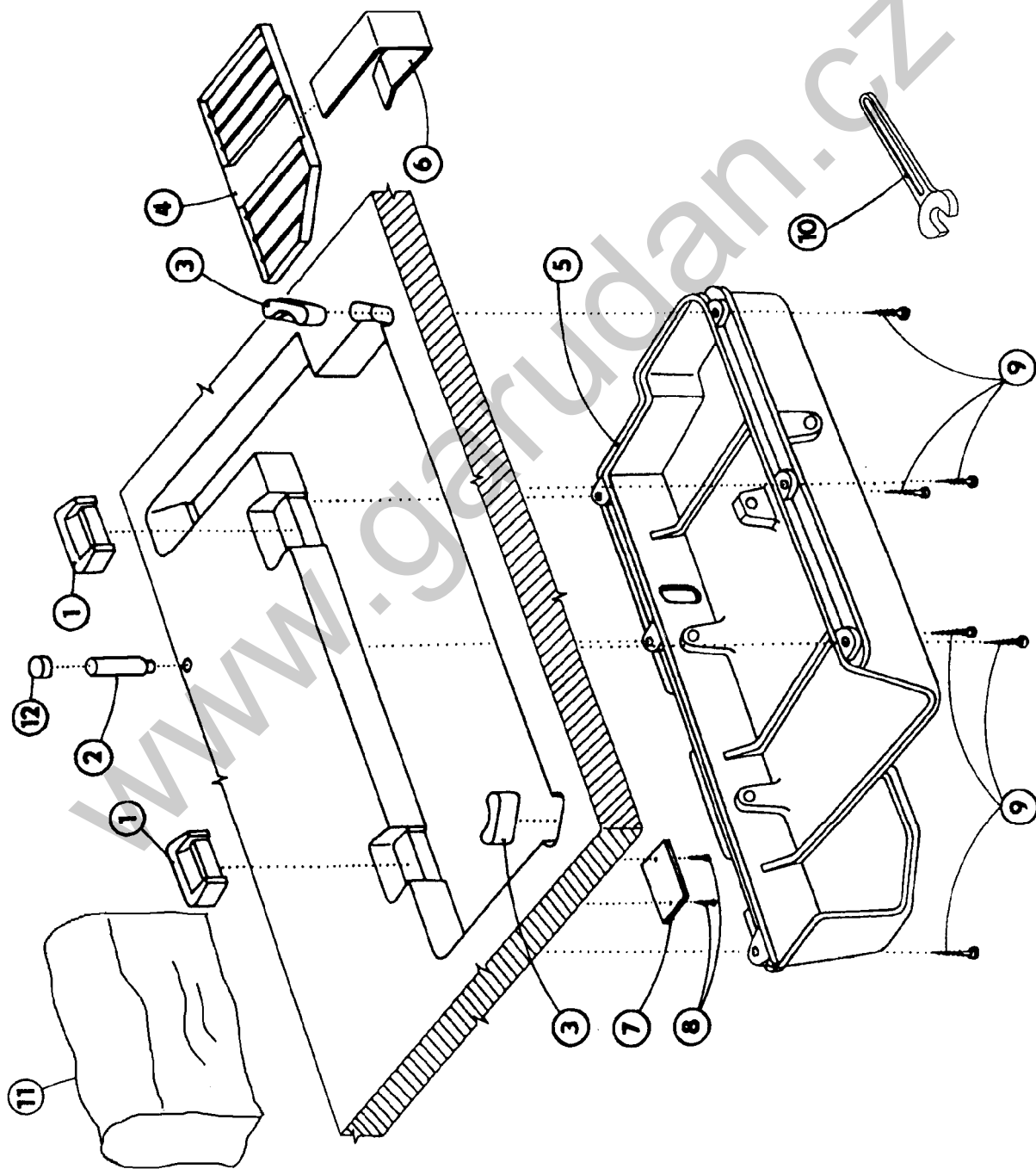

tab. 25

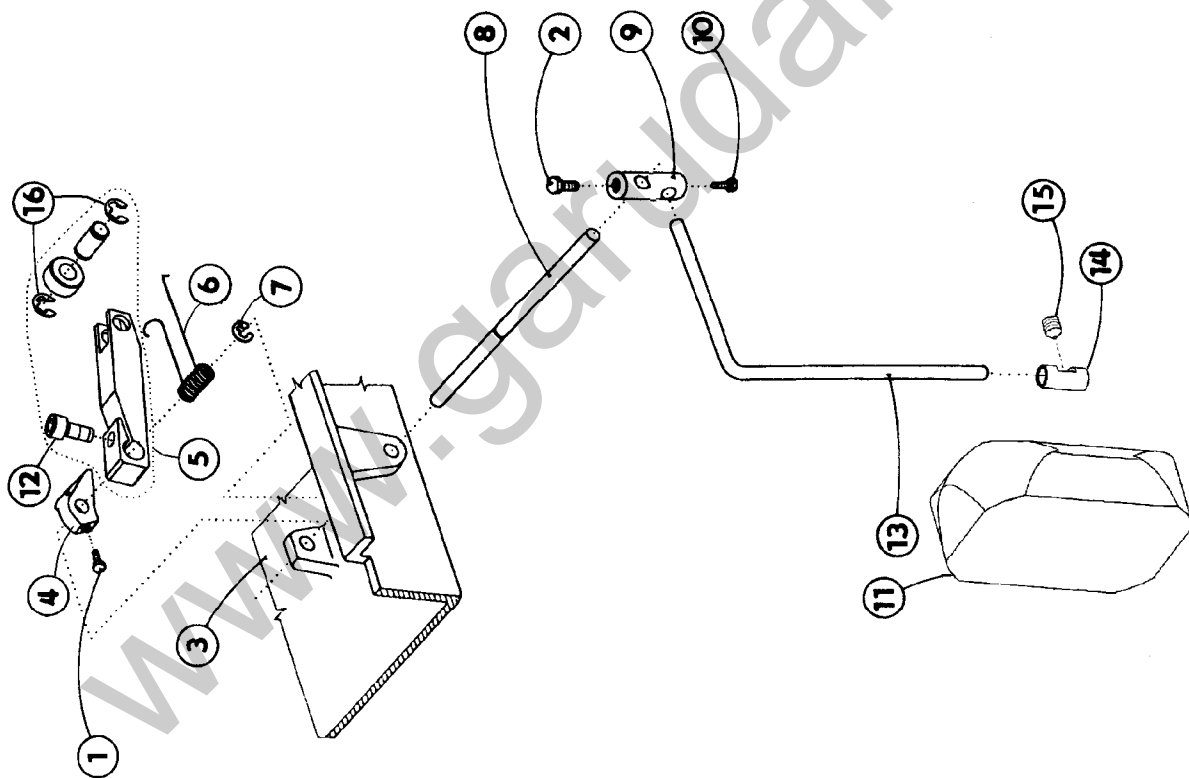

527 - 105

S980 099038 /2

- | | | |
|----|------|--------|
| 1 | S080 | 141141 |
| 2 | S080 | 141121 |
| 3 | S080 | 725050 |
| 4 | S080 | 625022 |
| 5 | S980 | 027603 |
| 6 | S080 | 264168 |
| 7 | S311 | 732070 |
| 8 | S080 | 314065 |
| 9 | S080 | 318069 |
| 10 | S080 | 141112 |
| 11 | 0396 | 130013 |
| 12 | S080 | 120295 |
| 13 | S080 | 383022 |
| 14 | S080 | 416146 |
| 15 | 9205 | 102788 |
| 16 | S311 | 732060 |

tab. 26

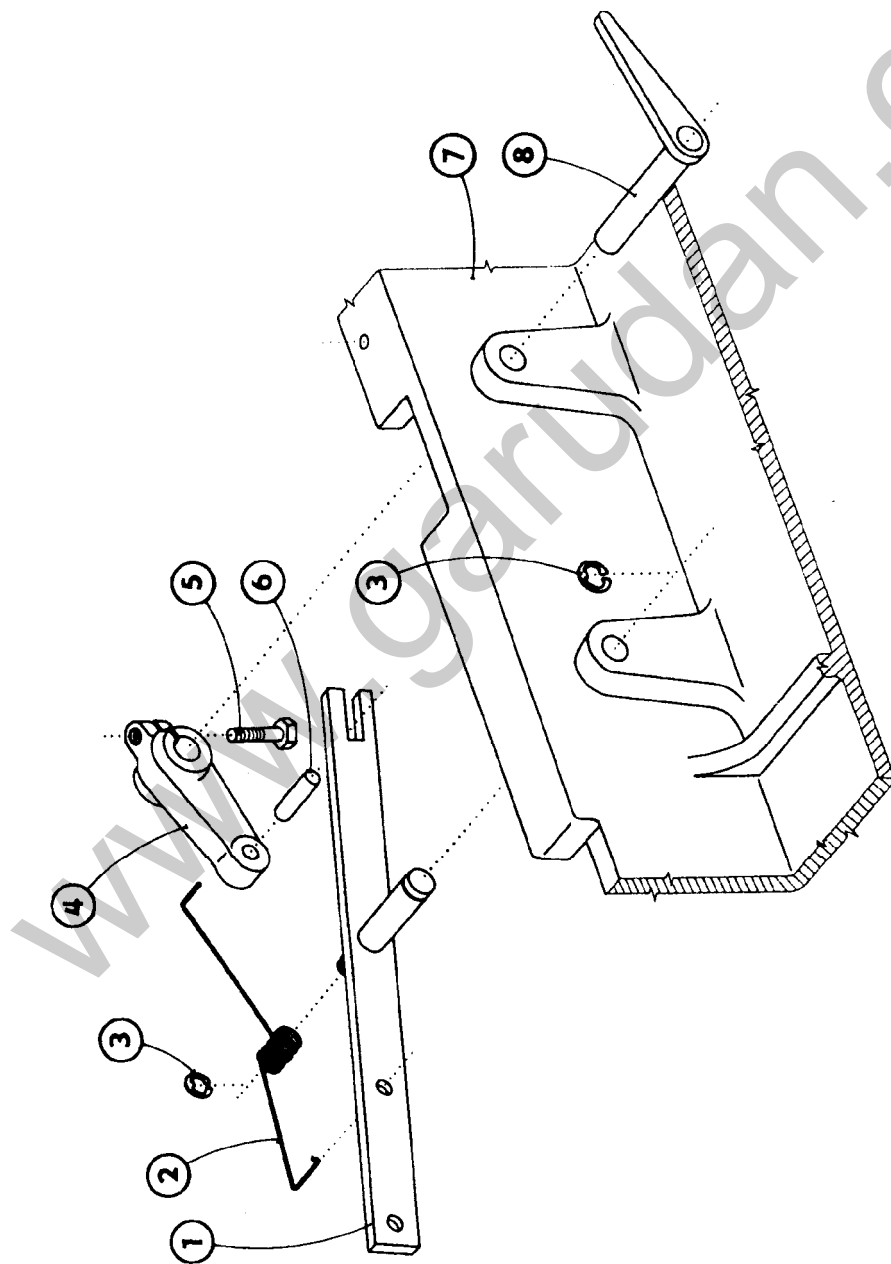

527 - 105

S980 099038 /3

- | | | |
|---|------|--------|
| 1 | S980 | 049109 |
| 2 | S080 | 264290 |
| 3 | S311 | 732070 |
| 4 | S080 | 613480 |
| 5 | S080 | 141109 |
| 6 | S311 | 515041 |
| 7 | S080 | 725050 |
| 8 | S980 | 044142 |

tab. 27

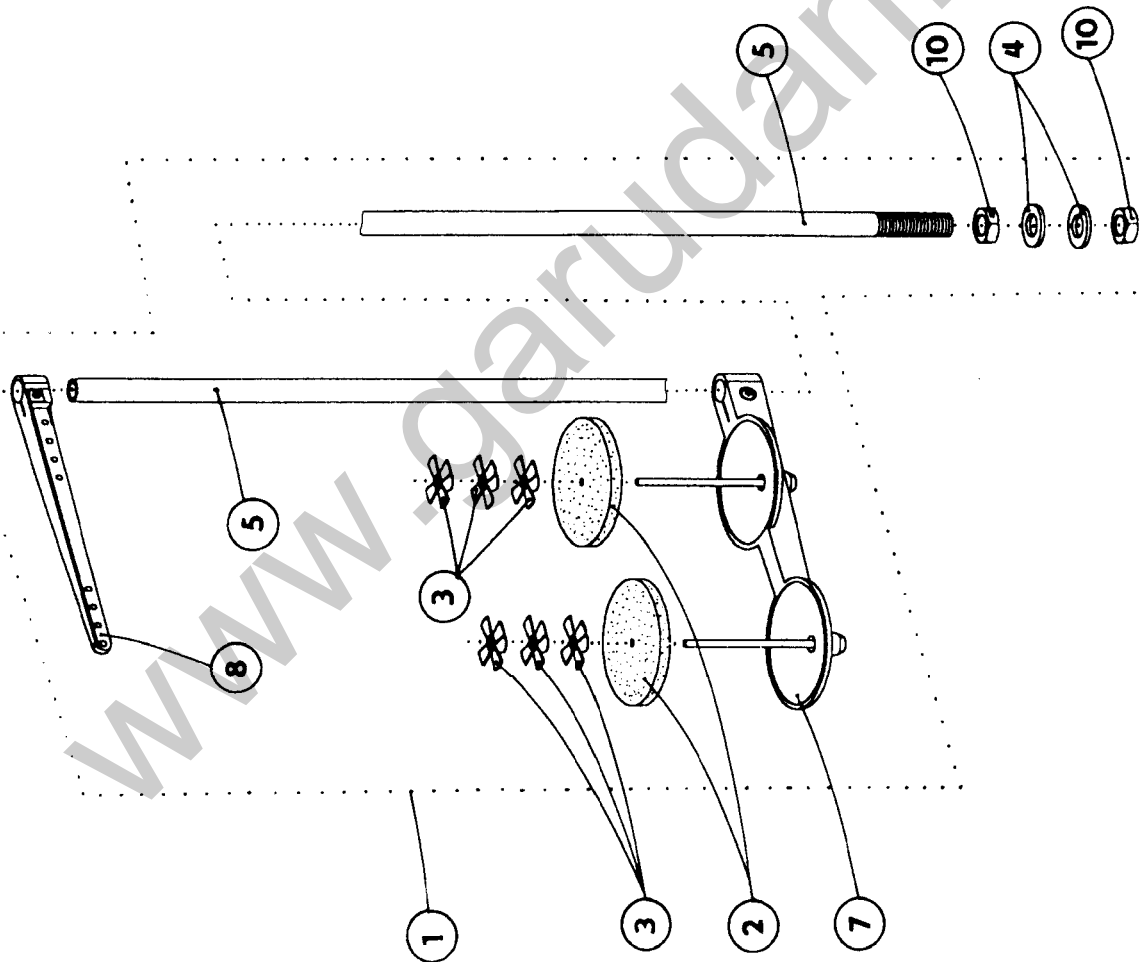

527 - 105

S980 099038 /4

1	S981	036163	
2	0077	110220	4 x
3	0077	110230	12 x
4	9330	000177	
5	0791	001081	
7	0791	001091	2 x
8	0791	001096	2 x
10	0995	340617	

527 - 105

S980 099038 /5

- | | | |
|----|-------------|---------------|
| 1 | S413 | 731023 |
| 2 | S080 | 818273 |
| 3 | S548 | 001000 |
| 4 | S413 | 310002 |
| 5 | S080 | 813481 |
| 6 | S413 | 000500 |
| 7 | S413 | 000400 |
| 8 | S662 | 002000 |
| 9 | S080 | 829796 |
| 10 | S980 | 092220 |

tab. 28

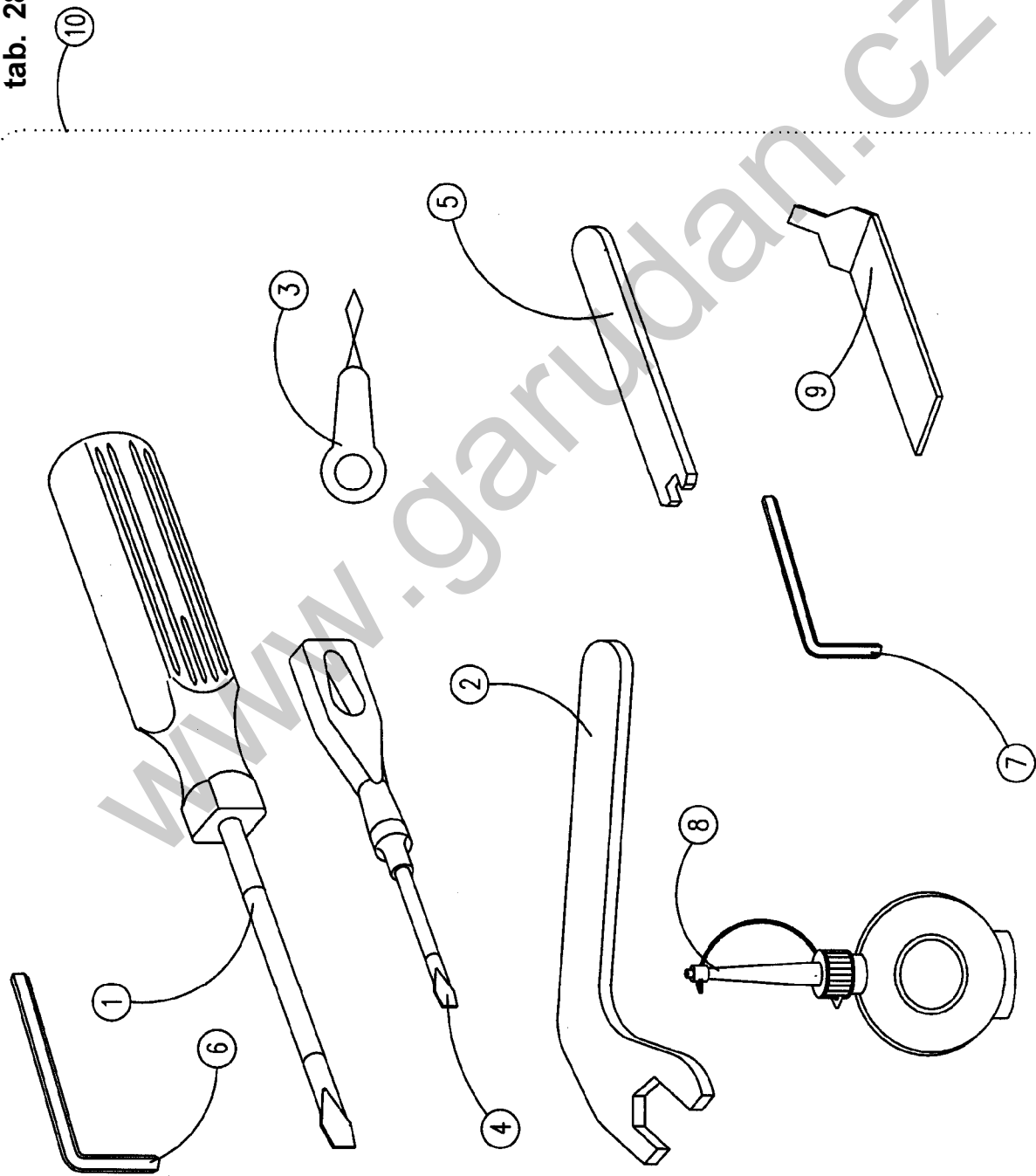

tab. 29

1

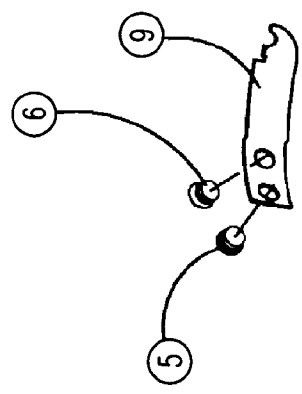
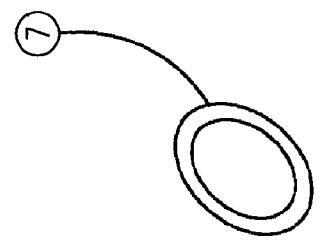
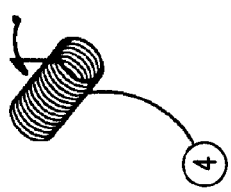

527 - 105

1	S980	092229	4 X
2	S080	265037	2 X
3	S321	953200	4 X
4	S315	264294	4 X
5	S080	683063	4 X
6	S080	683053	4 X
7	S273	025410	4 X
8	S080	685051	10 X
9	S080	690029	4 X

527 - 105

S980 094051

tab. 30

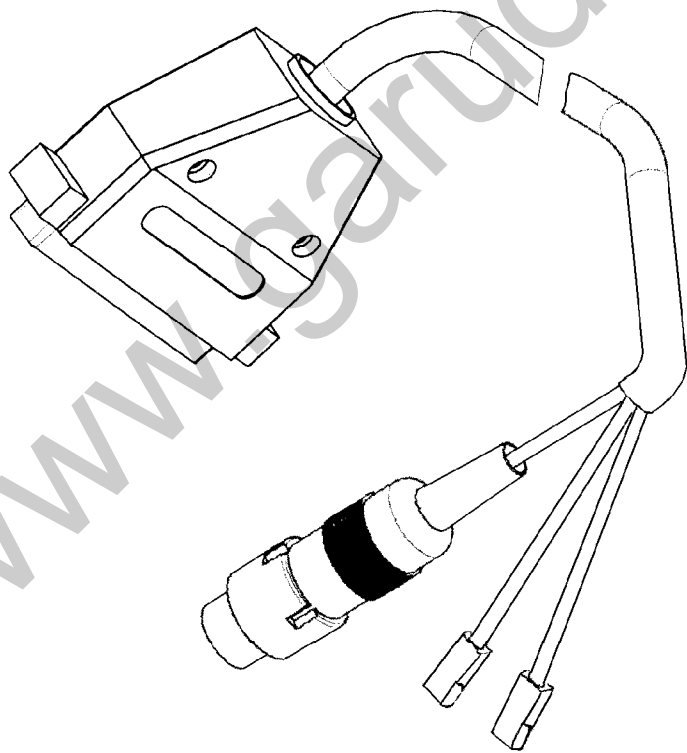

tab. 31

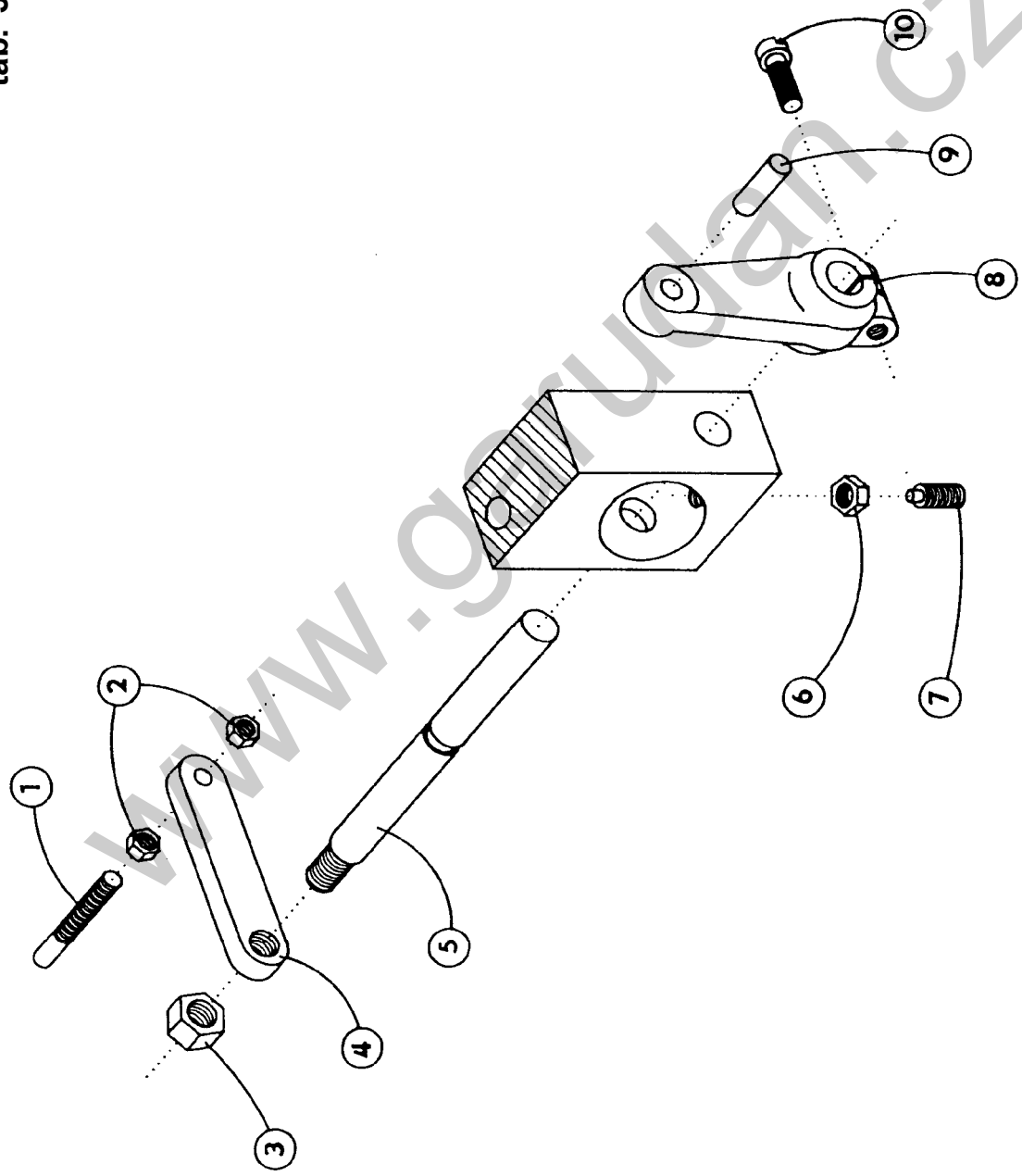

527 - 105

S791 995068

- | | | |
|----|------|--------|
| 1 | S080 | 316038 |
| 2 | S080 | 161143 |
| 3 | S080 | 161159 |
| 4 | S080 | 632019 |
| 5 | S080 | 342096 |
| 6 | S080 | 161140 |
| 7 | S080 | 111097 |
| 8 | S080 | 613480 |
| 9 | S311 | 515035 |
| 10 | S080 | 120230 |

527 - 105

527 E 461

S791 124061 35

- 1 134 No.100 - 11x
- 2 S980 031603
- 3 S080 811634
- 4 S080 651428

tab. 32

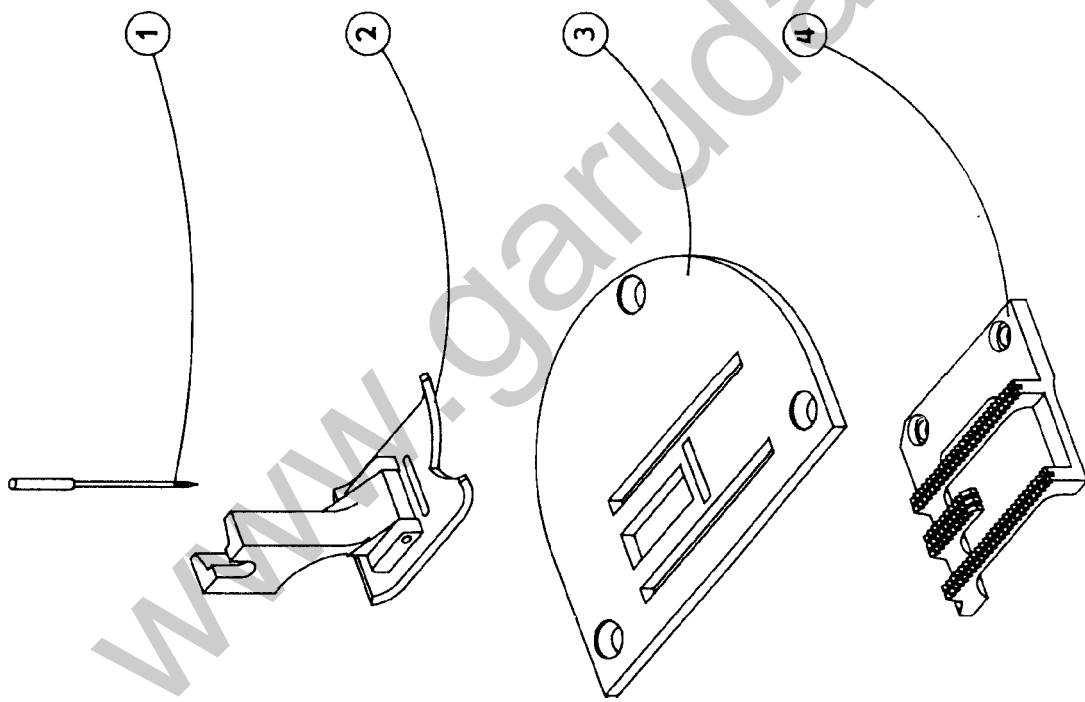

527 - 105

527 E 023

S791400023

1	S980	031604
2	S080	124061
3	S080	049443
4	S080	811633
5	S980	022282
6	S080	651428

tab. 33

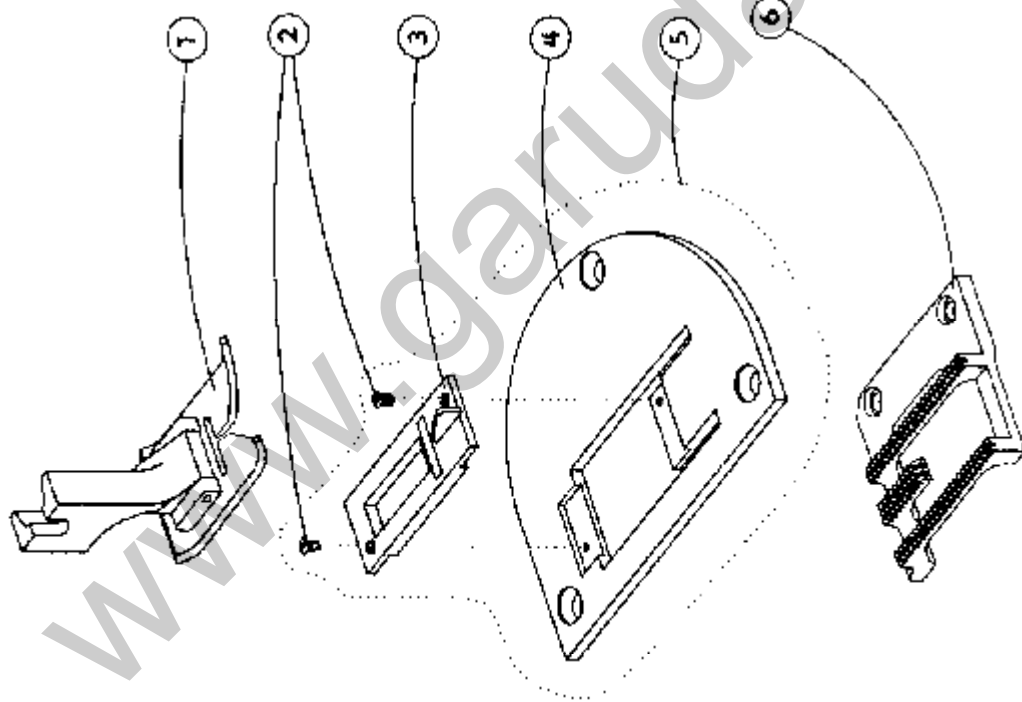

tab. 34

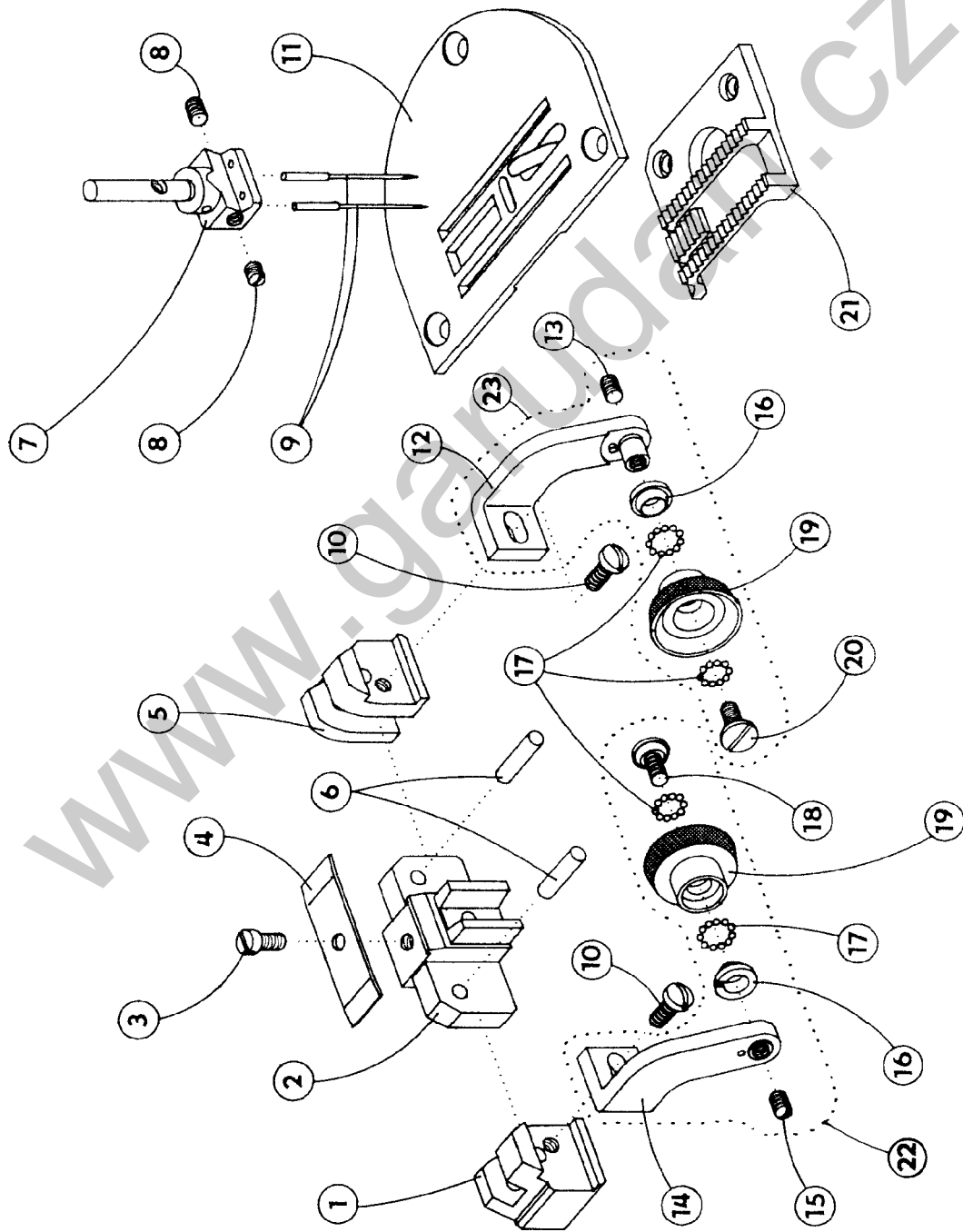

527 - 105

527 E 048
S791 430048 35/1

527 E 060
S791 430060 35/1 A

527 E 061
S791 430061 35/1 B

1	S080	646459
2	S080	743106
3	S080	120217
4	S080	281133
5	S080	646460
6	S311	515026
7	S080	394203
7	S080	394158 A
7	S080	394159 B
8	S080	111109
9	134 LR No.	130 - 12 x
9	134 LR No.	90 - 12 x A
9	134 LR No.	110 - 12 x B
10	S080	124086
11	S980	022840
11	S980	022867 A
11	S980	022868 B
12	S980	059054
13	S080	111212
15	S080	111142
21	S080	651499
21	S080	651509 A
21	S080	651510 B
22	S980	031645
23	S980	031646

tab. 35

527 - 105

527 E 048
S791 430048 35/2

527 E 060
S791 430060 35/2

527 E 061
S791 430061 35/2

- | | | |
|----|------|--------|
| 1 | S080 | 310436 |
| 2 | S080 | 112012 |
| 3 | S080 | 825733 |
| 4 | S080 | 190520 |
| 5 | S080 | 135023 |
| 6 | S080 | 120245 |
| 7 | S080 | 049805 |
| 8 | S080 | 118051 |
| 9 | S080 | 828051 |
| 10 | S080 | 271409 |
| 11 | S080 | 132163 |
| 12 | S080 | 313204 |
| 13 | S080 | 827174 |
| 14 | S080 | 262065 |
| 15 | S080 | 161146 |
| 16 | S081 | 200025 |
| 17 | S080 | 171030 |
| 18 | S080 | 161138 |
| 19 | S080 | 414023 |
| 20 | S315 | 264162 |
| 21 | S080 | 118003 |
| 22 | S080 | 195004 |
| 23 | S080 | 421129 |
| 24 | S311 | 515011 |
| 25 | S311 | 510008 |
| 26 | S080 | 828046 |
| 27 | S080 | 827048 |
| 28 | S315 | 262024 |
| 29 | S080 | 173017 |
| 30 | S080 | 828048 |
| 31 | S080 | 418039 |
| 32 | S080 | 828047 |
| 33 | S080 | 171023 |
| 34 | S980 | 025271 |
| 35 | S980 | 025272 |

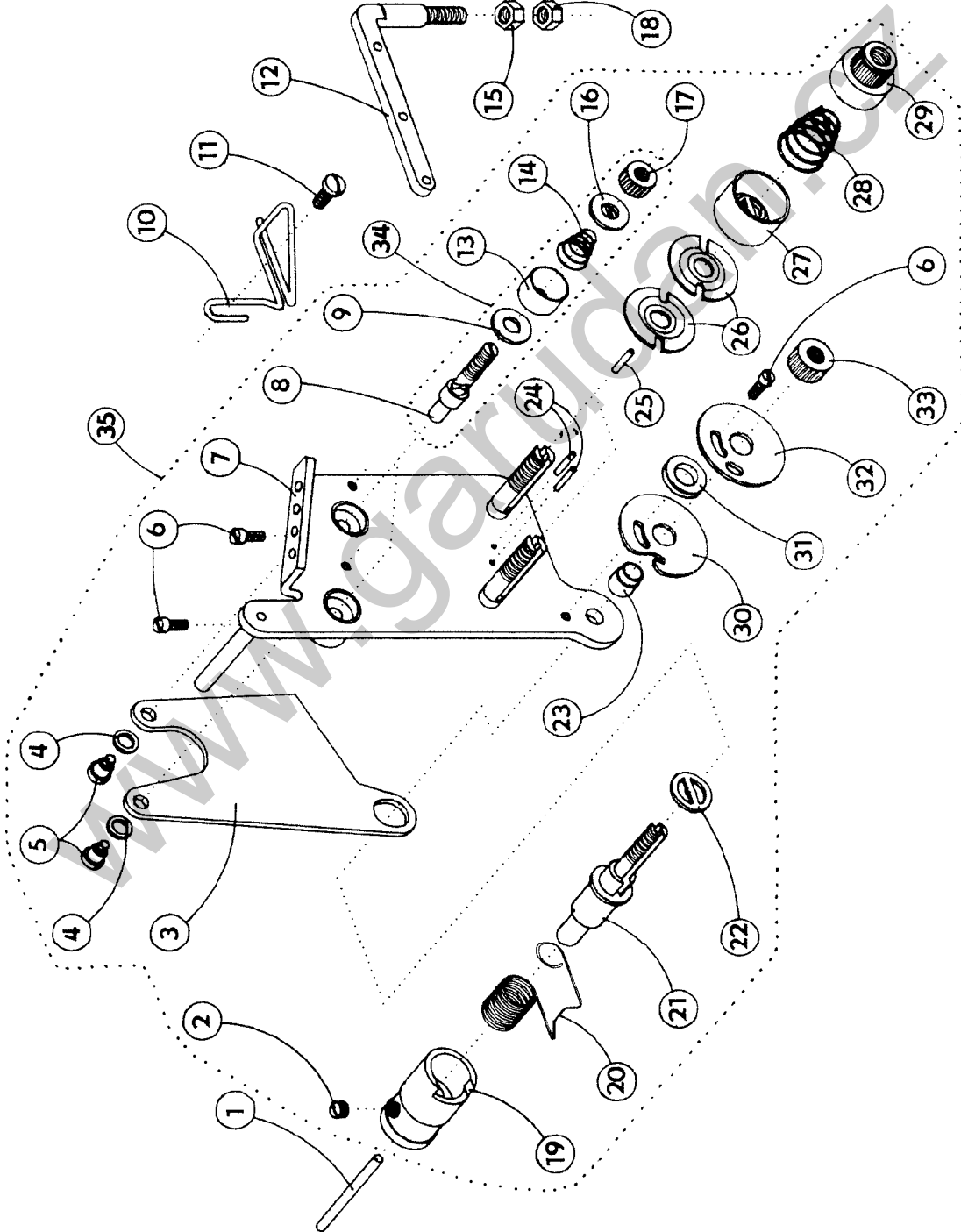

tab. 36

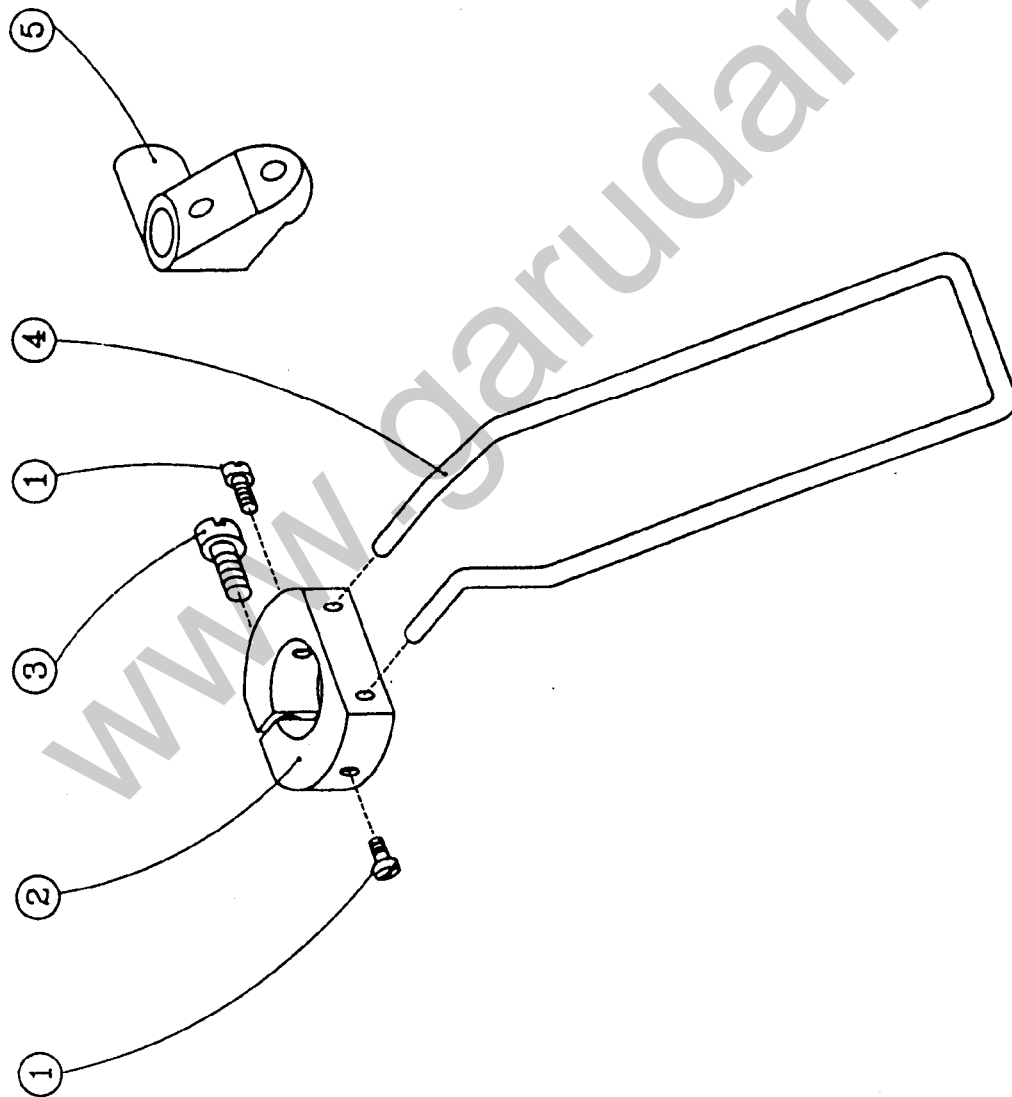

527 - 105

527 N001

S791 149001

1	S080	120 037
2	S080	646 136
3	S080	120 225
4	S080	271 441
5	S080	627 037

527 - 105

**525 E017
S791 151017**

1 S980 031652

X = 10 mm

tab. 37

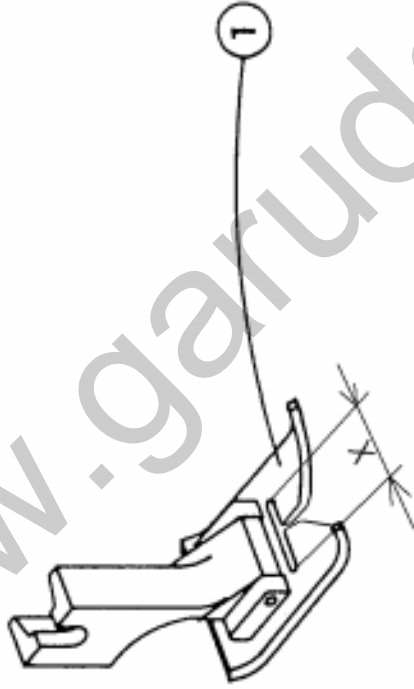

527 - 105

S791995153

- | | | |
|---|------|--------|
| 1 | S980 | 060208 |
| 2 | S080 | 260610 |
| 3 | S080 | 120354 |
| 4 | S981 | 094041 |
| 5 | S080 | 831699 |
| 6 | S321 | 000000 |

tab. 38

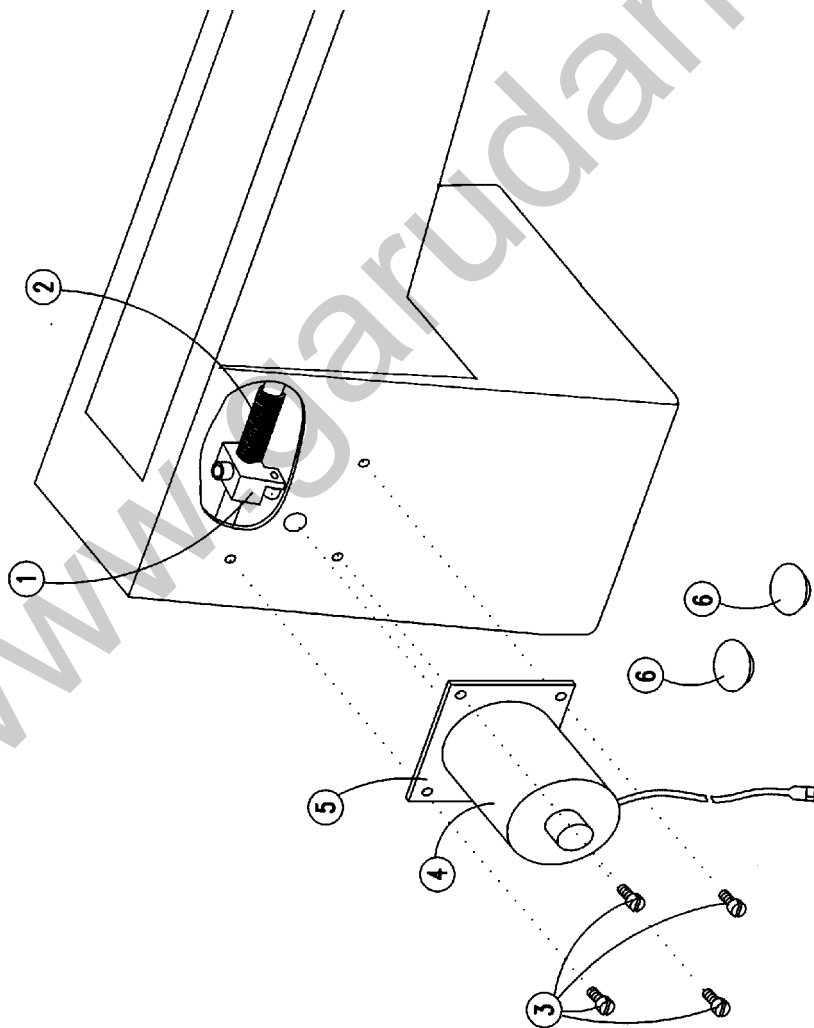

tab. 39

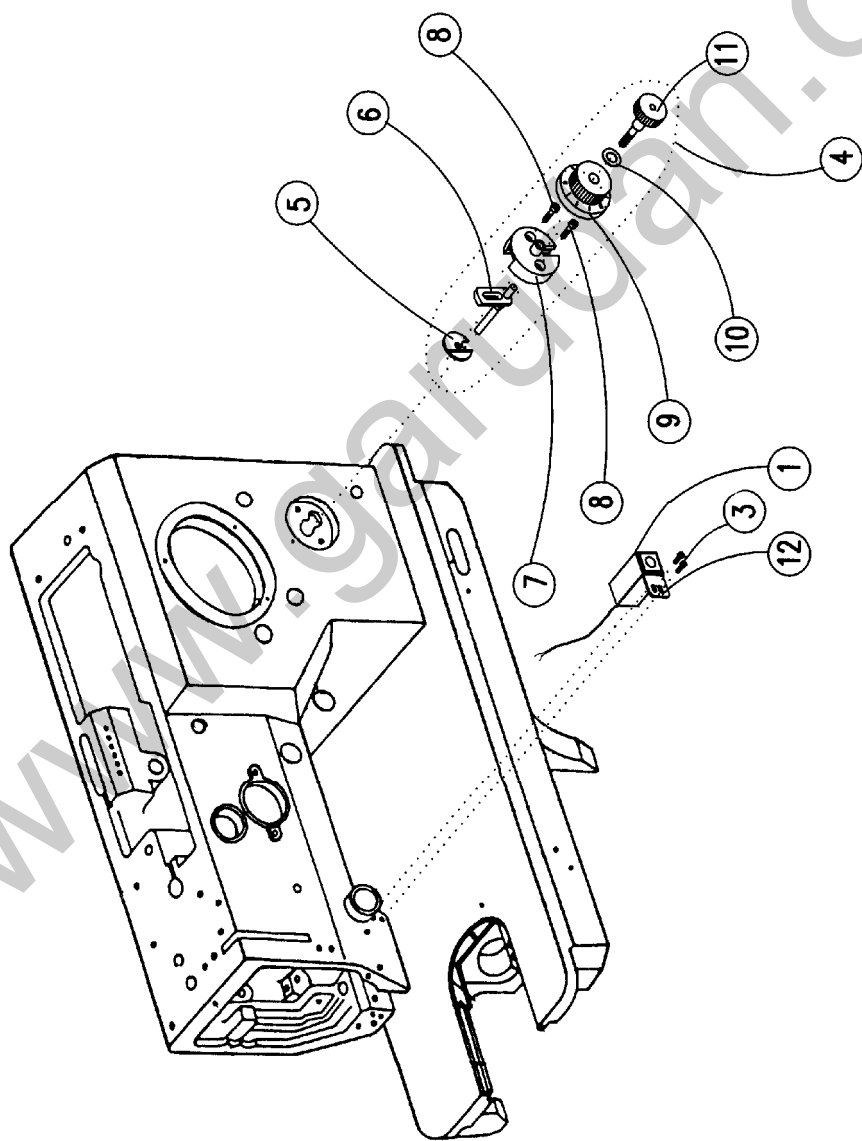

527 - 105

1	S980 094057
1	S980 094060
	S791 995154/1
3	S080 132153
4	S980 044895
5	S080 441550
6	S980 043369
7	S080 441475
8	S080 120219
9	S980 233053
10	S080 190483
11	S080 342270
12	S980 035914

tab. 40

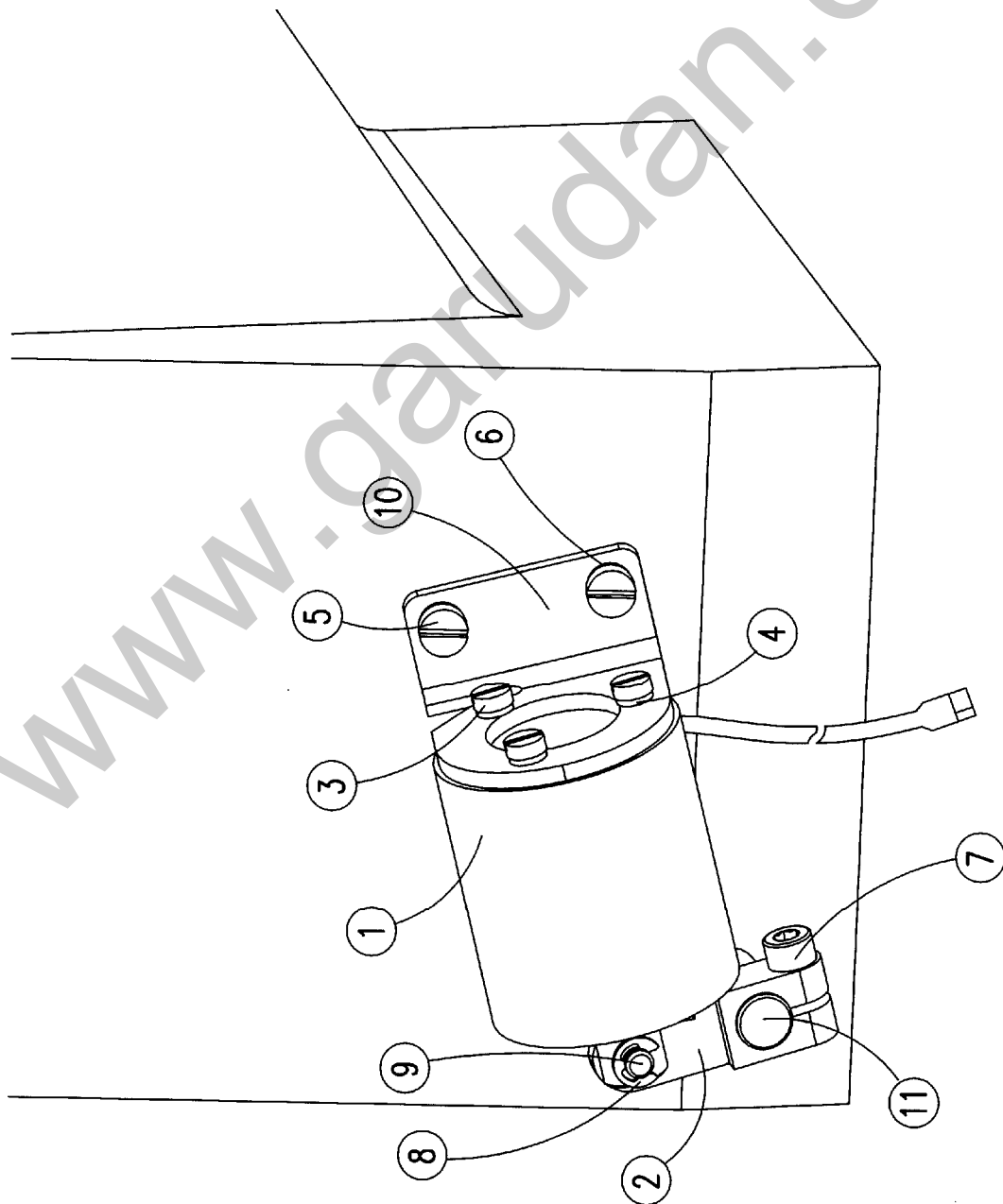

527 - 105

S791995154/2

1	S980	094047
2	S080	613594
3	S080	120331
4	S080	191135
5	S080	120354
6	S080	191136
7	S080	120364
8	S311	732040
9	S080	314231
10	S080	826396
11	S080	342342

tab. 41

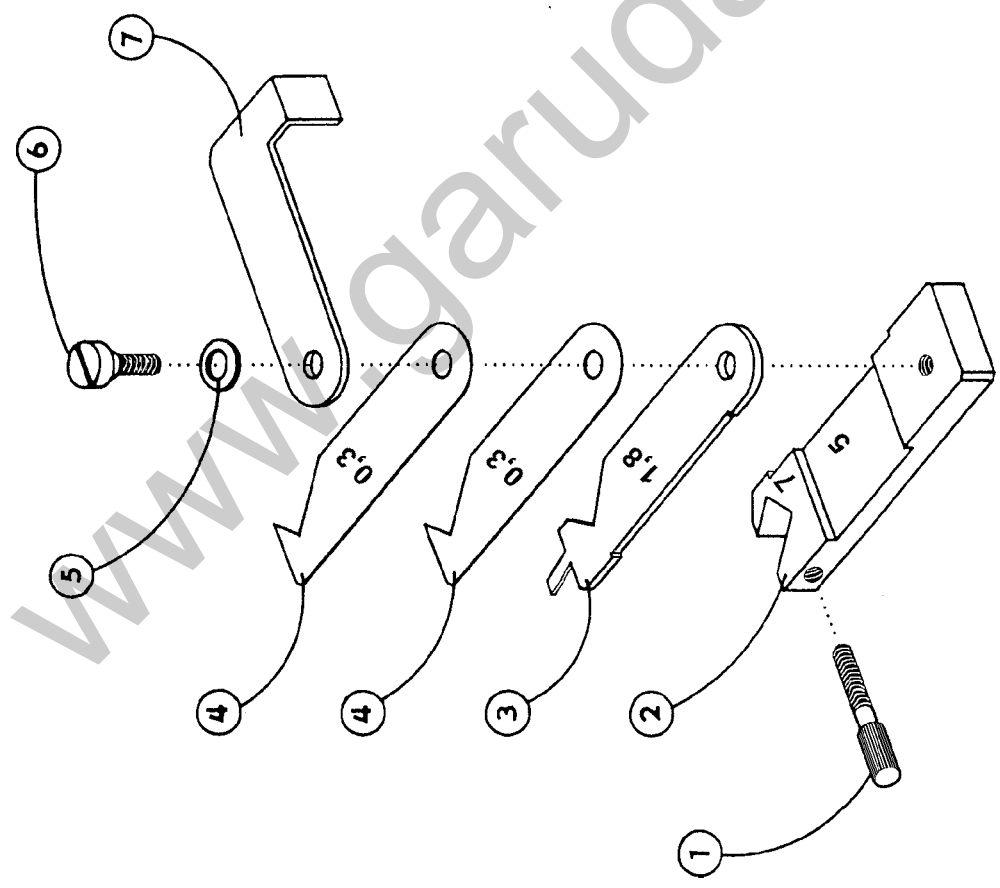

527 - 105

Z 001

S791947001

















- | | | |
|---|------|--------|
| 1 | S080 | 133112 |
| 2 | S080 | 646148 |
| 3 | S080 | 814365 |
| 4 | S080 | 814364 |
| 5 | S080 | 192061 |
| 6 | S080 | 131404 |
| 7 | S080 | 831412 |

527 - 105

527 Z 504

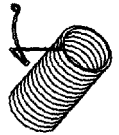
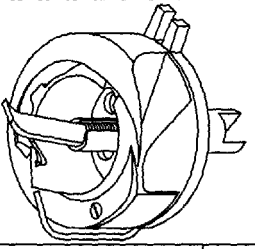
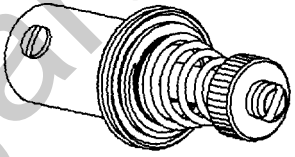
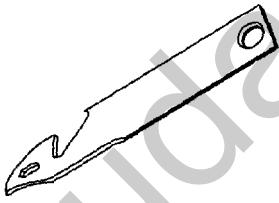
S741 41050440

tab. 42

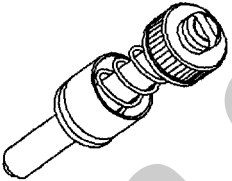
3x S080 11109 	3x S080 141088 	5x S080 683053 	5x S080 683053 	3x S080 135029 	3x S080 120239 
5x S080 123117 	3x S080 265037 	1x S080 627170 	3x S080 136082 	3x S080 124050 	5x S080 112013 
3x S080 690029 	5x S315 264294 	1x S980 008251 	1x S980 025244 	1x S080 870167 	3x S273 025410 
3x S080 132216 	1x S080 264281 	1x S080 870140 			1x S980 025160 

tab. 43

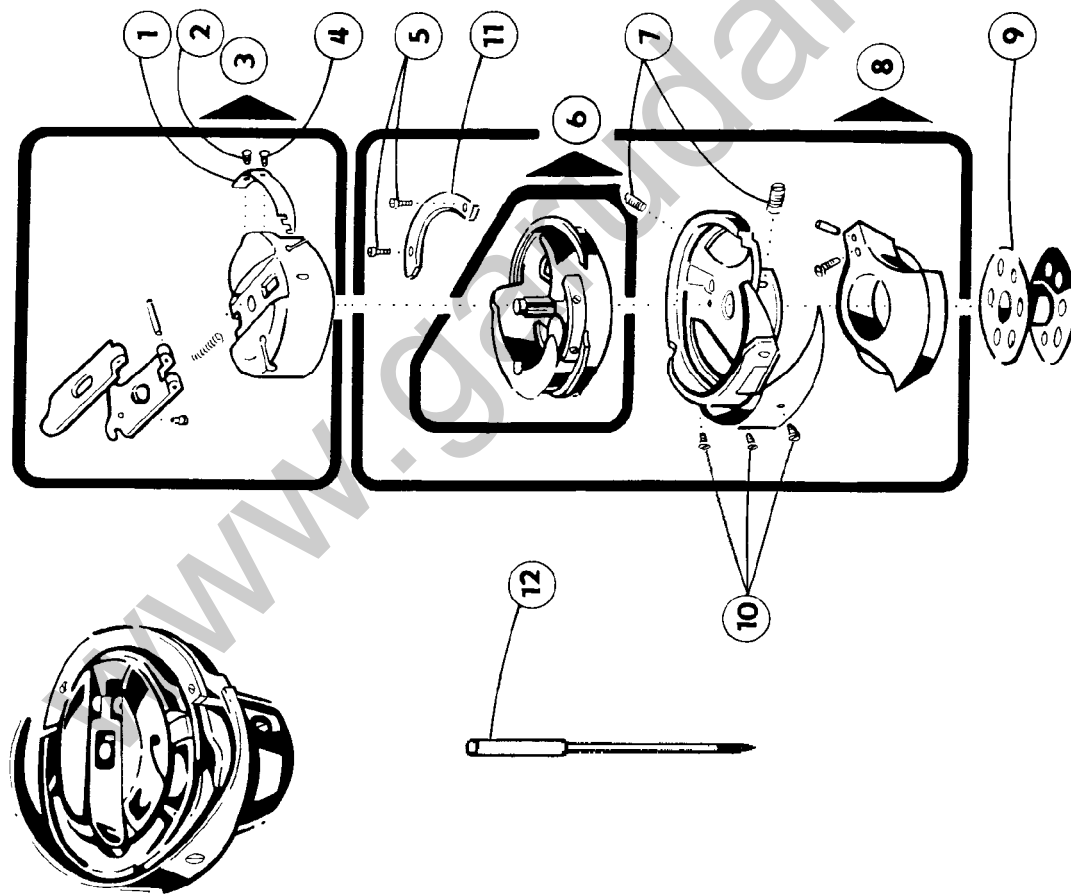

527 - 105

527Z 055

S791 430055 35

- 1 S080 690029
- 2 S080 683063
- 3 S980 081122
- 4 S080 683053
- 5 S080 683064
- 6 S980 081161
- 7 S080 683067
- 8 S980 081160
- 9 S080 685051
- 10 S080 683083
- 11 S080 681029
- 12 134 No. 160 - 12x

527 - 105

Z 012

S794 222012

1	S080	120692
2	S080	190346
3	0798	500088
4	0907	487519
5	9822	510001

tab. 44

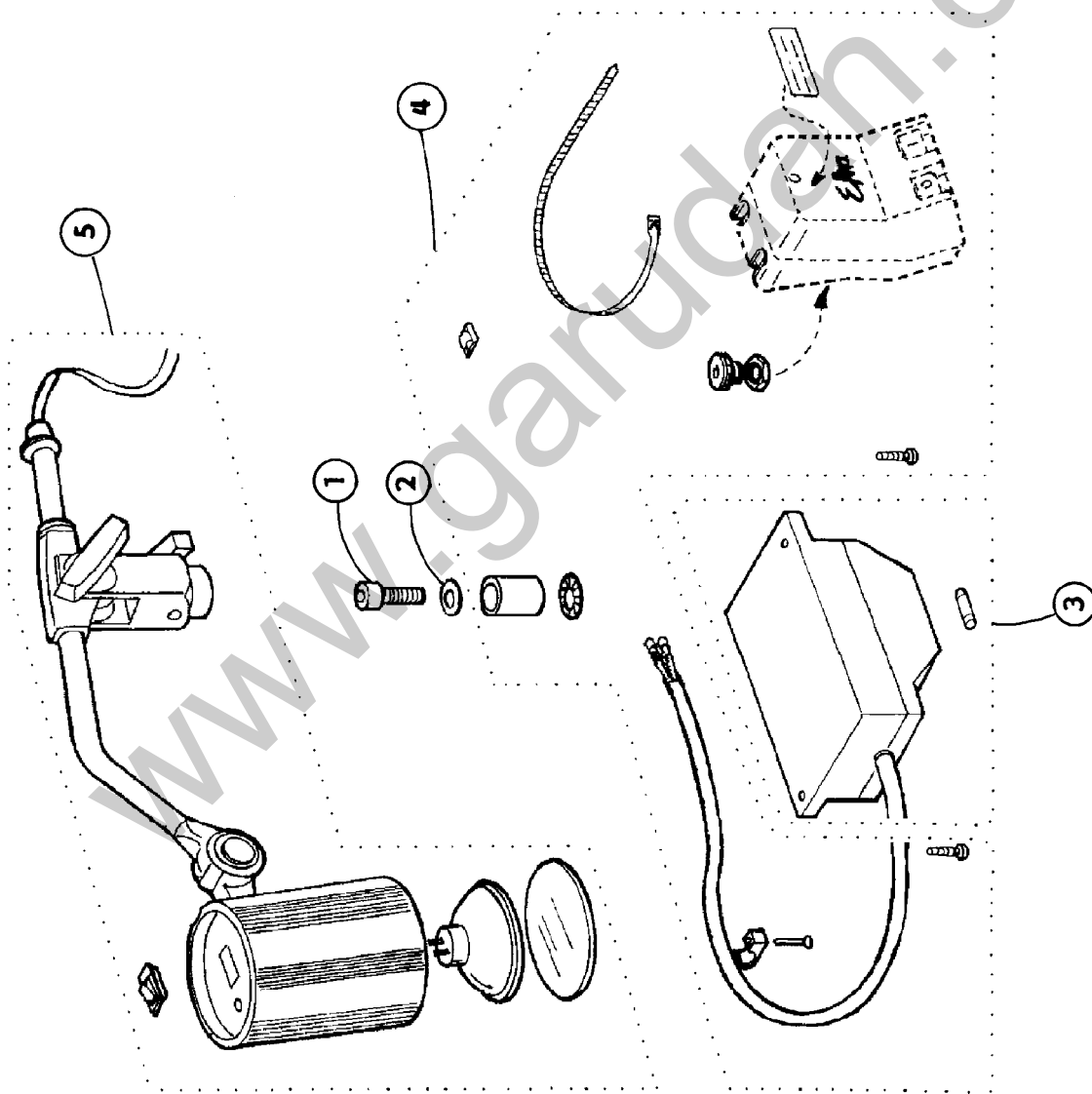

527 - 105

tab. 45

www.garudan.cz