

MODEL **ST-260.4**  
**ST-360.4**

**INSTRUCTION BOOK AND PARTS BOOK**

**SU LEE MACHINE .CO.,LTD.**

## IMPORTANT SAFETY INSTRUCTIONS

When using your cutting machine, basic safety precautions should always be followed, including the following

1. Read all instructions.
2. Use machine only for its intended use a portable cutting machine
3. Turn machine to "OFF" before connecting or disconnecting power cord.
4. Do not install or store this machine in a wet location.
5. Keep area around machine free from the accumulation of lint.
6. Always disconnect machine from electrical connector when not in use, before servicing, and when changing blades
7. Do not operate machine with a damaged cord or if machine has been dropped. Do not disassemble; take to qualified serviceman for repairs. Incorrect reassemble can cause electric shock when the machine is used.
8. Keep visitors away. Do not leave machine unattended while it is connected.
9. Keep hands away from blade.
10. Be sure machine is properly grounded while in use to protect the operator from electrical shock.
11. Keep machine clean and blade sharp for best and safest performance.
12. The knife key and other wrenches must be removed from machine before starting motor.
13. Keep guards in place and in working order.

**Save These Instructions**

## 重要安全指導

當你使用斷布機時,必須遵守以下的安全警告指示

1. 閱讀所有的指示說明。
2. 由經訓練的專人使用操作。
3. 接上或取下電源時, 機器開關必須先關閉。
4. 勿將機器安裝或存放於潮濕的地方。
5. 機器周圍地區保持乾淨, 遠離棉, 毛絮堆積。
6. 當機器不使用或保養、維修、更換砂輪、刀片等零件時, 必須先拔下電源。
7. 請勿自行分解拆裝, 應交由合格的技師進行維修, 不正確的拆裝將造成電機的損毀和故障
8. 非操作人員請勿靠近, 操作人員不在時請拔掉電源。
9. 保持注意手遠離刀片。
10. 確定電源接地。
11. 保持機器清潔和刀片鋒利, 以備最佳使用狀態。
12. 更換刀片務必確定鎖緊並移除相關工具。
13. 安全護蓋裝置使用前必須裝好固定。

**謹記以上說明**

## INSTRUCTION MANUAL

- 1.1 Connect the terminal,grind the knife 2~3times,reset the counter to 0000,counter switch is turn ON.
- 1.2 See pictuer 1-1,pall cloth to end rail.
- 1.3 See pictuer 1-2,Lift rail to press clothe.
- 1.4 See pictuer 1-3,Push button switch on,and pull cutter cut off cloth in a straight line.
- 1.5 See pictuer 1-4,Lift end rail then put down.

### 操作說明

- 1.1 接通電源,磨刀 2~3 次,將計數器歸零,計數器開關置於零 ON.
- 1.2 依圖 1-1 所示,將布拉至尾壓布器.
- 1.3 依圖 1-2 所示,將布壓夾於裁床.
- 1.4 依圖 1-3 所示,按切布開關,起動切刀向前推,將布切斷.
- 1.5 依圖 1-4 所示,抬起軌道,使布料自行落下,並放下軌道,將布料壓固於裁床.

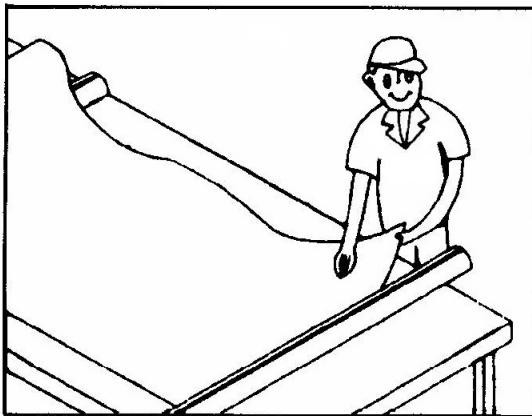

1-1

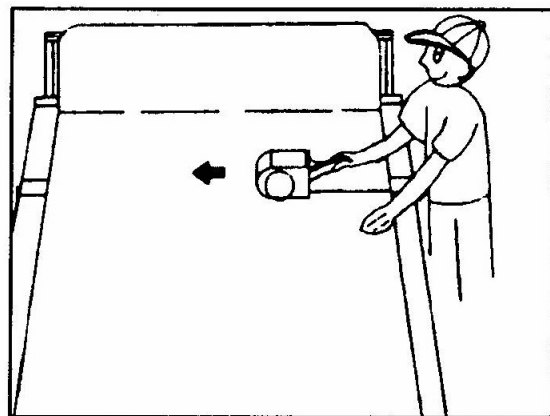

1-3

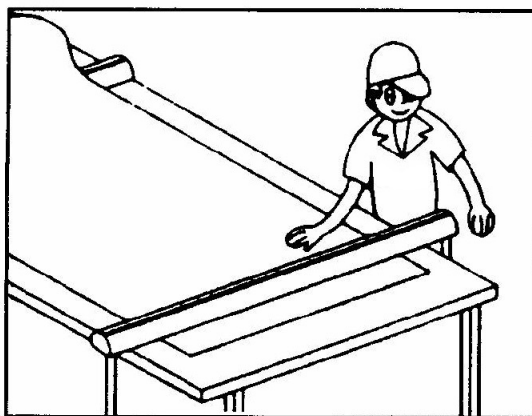

1-2

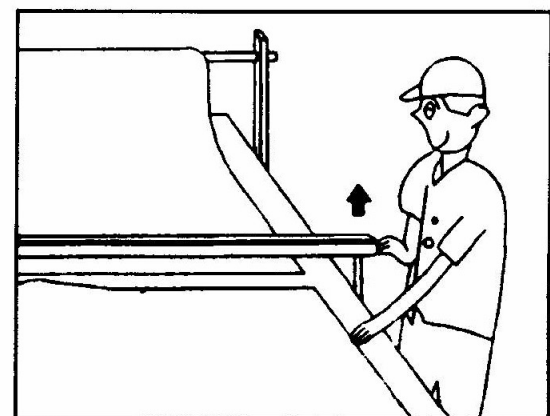

1-4

## INSRUCTION AND PROCESS OF INSTALLATION

- 2.1 Align the right foot rest 263946N-R and the left foot rest 263946N-L and secure both on the cutter.
- 2.2 Place the right hoist rod 264749N from top to bottom into the pulley groove of the right rest 263946N-R and the left hoist rod 264750N from top to bottom into the pulley groove of the left rest 263946N-L.
- 2.3 As shown in Fig.2-2, secure one end of the hoist belt 2662 onto the right rest 263946N-R and the other end onto the pulley on top of the left hoist rod 264750N through the pulley 2649 on top of the pulley of pulley set 2650. (Note: the hoist belt must be tightened and the right hoist rod 264749N and the left hoist rod 264750N shall be kept at the same level)
- 2.4 Place the track 265359 at equal distance on top of the right rod 264749N and the left hoist rod 264750N, while securing both using the track securing screw 2660.
- 2.5 Place the left end of the track into the track end lid 2655N and lock it using screw PRM0510.
- 2.6 Place in the fabric-cutting machine 260138 and drop in some sewing machine oil into the track.
- 2.7 Place the right end of the track into the track lid 2655N and lock it using screw PRM0510.
- 2.8 Hang the lift aid spring 2644-A on the right rest under the right hoist rod 264749N (as shown in Fig.2-1)
- 2.9 Mount the fabric rack 2651 as shown on the cutting bed.
- 2.10 Plug in the power cord 523C1 to finish the process.

## 安裝說明

- 2.1 將右腳架組 263946N-R 與左腳架組 263946-L 對齊, 緊固於裁床兩旁.
- 2.2 右升降組 264749N 由上而下放入右腳架組 263946N-R 之內, 左升降桿組 264750N 由上而下放入左腳架組 263946N-L 之滑槽內.
- 2.3 如圖 2-2 所示, 將升降帶 2662 一端緊固於右腳架組 263946N-R, 另一端經右升降桿組 264749N 上端之滑輪 2649 到對面左升降桿組 264750N 上方之滑輪, 再穿過滑輪組 2650 之滑輪往上, 最後緊固於左腳架組.  
(注意: 升降帶必須拉緊, 並使右升降桿組 264749N 與左升降桿組 264750N 同等高度)
- 2.4 軌道 265359 等距置放於右升降桿組 264749N 及左升降桿組 264750N 上方以軌道固定螺絲 2660 固定.
- 2.5 軌道左端置入軌道端蓋 2655N, 用螺絲 PRM0510 鎖上.
- 2.6 放入切布主機 260138, 並於軌道內滴入少許針車油潤滑.
- 2.7 軌道右端置入軌道端蓋 2655N, 用螺絲 PRM0510 鎖上.
- 2.8 將右腳架組上之提升輔助彈簧 2644-A 掛於右升降桿組 264749N 之下方 (如圖 2-1 所示).
- 2.9 撐布架組 2651 依圖於組裝於裁床.
- 2.10 插上電源插頭線 523C1 即可.

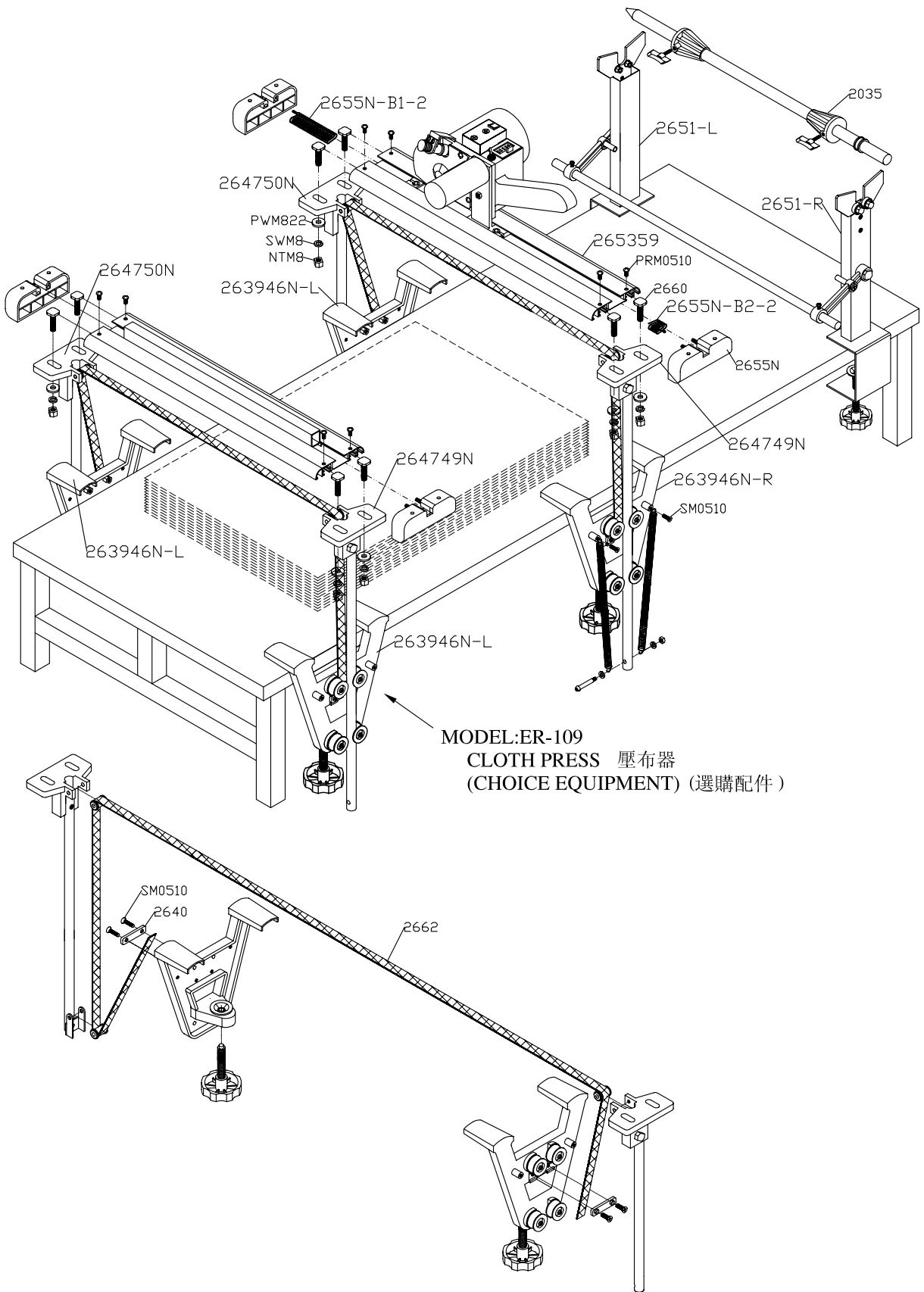

## CHECKING (Release connecting plugs)

- 3.1 Every 24 hours, Clean the Rail bar.
- 3.2 Every 200 hours, Give oil to roller 2611-BN
- 3.3 Adjustment of Re-sharpener:  
While the grinding wheel wears ,loosen stop nut of collar holder and rectify the re-sharpener position so as to the grinding wheel keeps proper contact with the knife edge.
- 3.4 Replacement of Grinding wheel,See Grinding wheel Replacement Guide.
- 3.5 Replacement of knife:
  1. Remove the knife guard 2633 and knife cover 2633C.
  2. Lock the knife to the Standard 2609,insetting 2.5mm spanner 2666 to hole in the knife.  
The corresponding hole for locking knife is also provided in the standard ,Remove knife lock hut 2630N  
by turning it left Use the wrench 2666 attached.
  3. Remove knife.
  4. Be sure the front face of the knife when re-setting the knife “SU LEE ST-260”markde face is the front face.
  5. Adjust the position of re-sharpener 2626 after each replacement of knife.
- 3.6 Replacement of Carbon Brush
  1. Too much weaving of carbon brush will cause motor troubles. Carbon brush must be replaced when it wears to 5-6mm.
  2. Carbon brush cap S105 is replaced by turning it left by attached wrench.
  3. Always replace right and lift carbon brushes simultaneously.
  4. Be sure to hold metallic part of the brush , keep fingers away from carbon.

## 保養與檢修（注意:將插頭拔掉）

- 3.1 每使用 24 小時,清理軌道內部之棉布絮.
- 3.2 每使用 200 小時,請於滑輪 2611-BN 處加少許潤滑油.
- 3.3 磨刀石的調整:  
當刀片磨損時,將磨刀石螺絲放鬆,調整磨刀石位置,使砂輪與刀片的邊緣保持正確的接觸面,在將螺絲旋緊即可.
- 3.4 砂輪的更換請看圖解所示.
- 3.5 刀片的更換:
  - 1.將前護片 2633 及刀片護蓋 2633C 取下.
  - 2.使用內六角扳手 2667 插入刀片孔內,使刀片卡鎖在馬達座 2609 上,不會轉動,再使用鎖刀扳手 2666 將鎖刀螺帽 2630N 依反時針方向轉開.
  - 3.取下刀片.
  - 4.裝刀片時請確定刀片上印有“SU LEE ST-260”字樣的一面,即正面朝向外面,人可看到.
  - 5.每次更換刀片後,須將磨刀石 2626 重新調整至適當位置.
- 3.6 碳刷的更換:
  - 1.碳刷磨損太多時,可能損壞馬達,當碳刷磨損到長度剩下 5~6MM 即可更換.
  - 2.只須將碳刷蓋 S105 轉開即可取出舊碳刷,再將新碳刷置入,將碳刷蓋旋上即可.
  - 3.通常更換碳刷時,請將左右兩個同時更換.
  - 4.裝入時,請確認碳刷有接觸在金屬整流子上,勿用手碰碳刷.

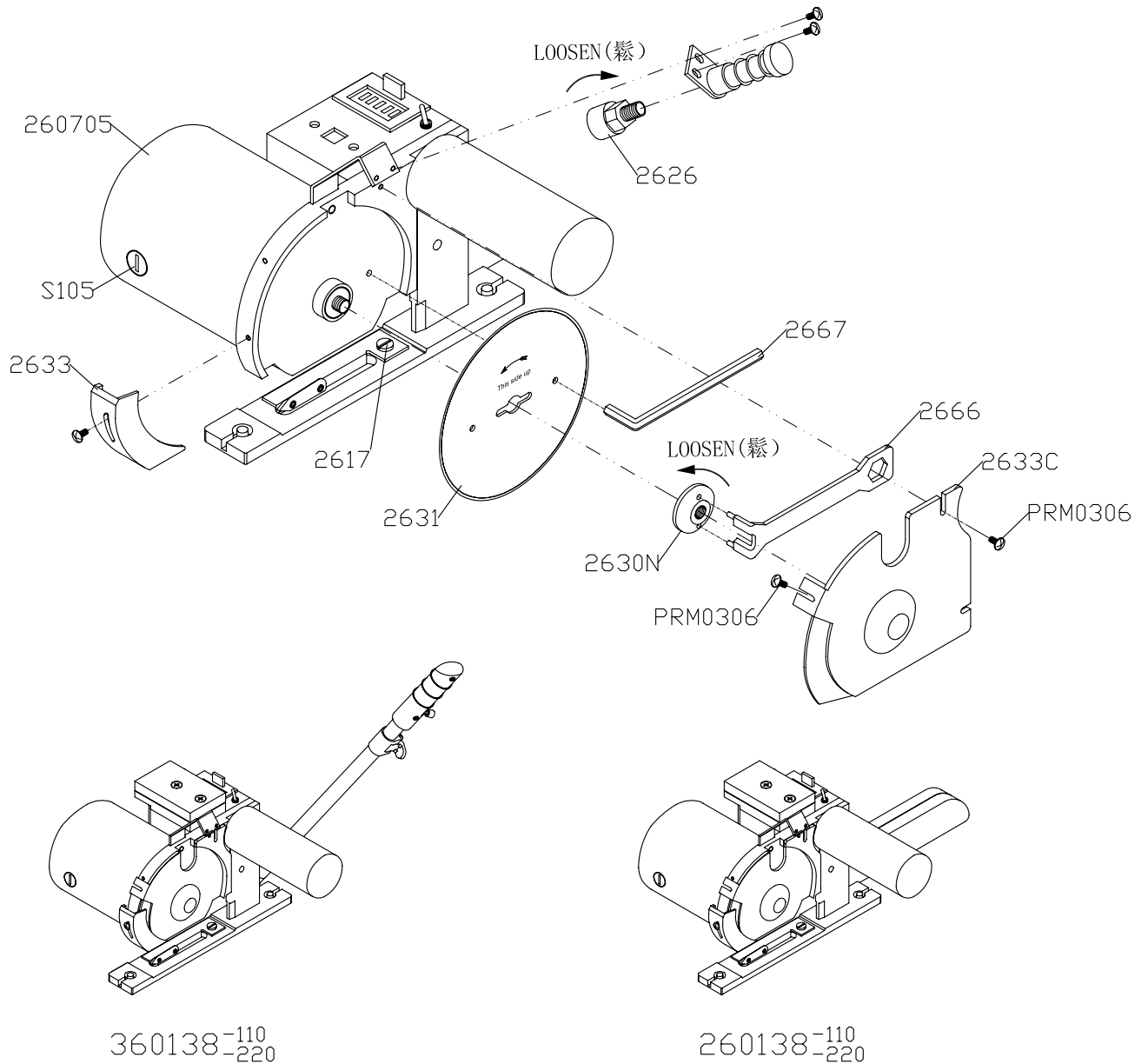

**SPECIFICATIONS:**

Knife Size :108mm(4 ¼inches)  
 Knife Shape :Round  
 Cutting Capacity :10mm  
 Voltage :Single Phase 100V~120V  
 or 220V~240V  
 Cycle :50~60Hz  
 Power :130W

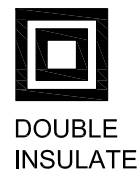

規格:  
 刀片尺寸 :108mm(4 ¼英寸)  
 刀片形状 :圓刀  
 裁斷能力 :10mm  
 電 壓 :單相 100V~120V  
 或 220V~240V  
 頻 率 :50~60Hz  
 輸出功率 :130W



\* 生產者保留變更規格不另行通知之權利 \*

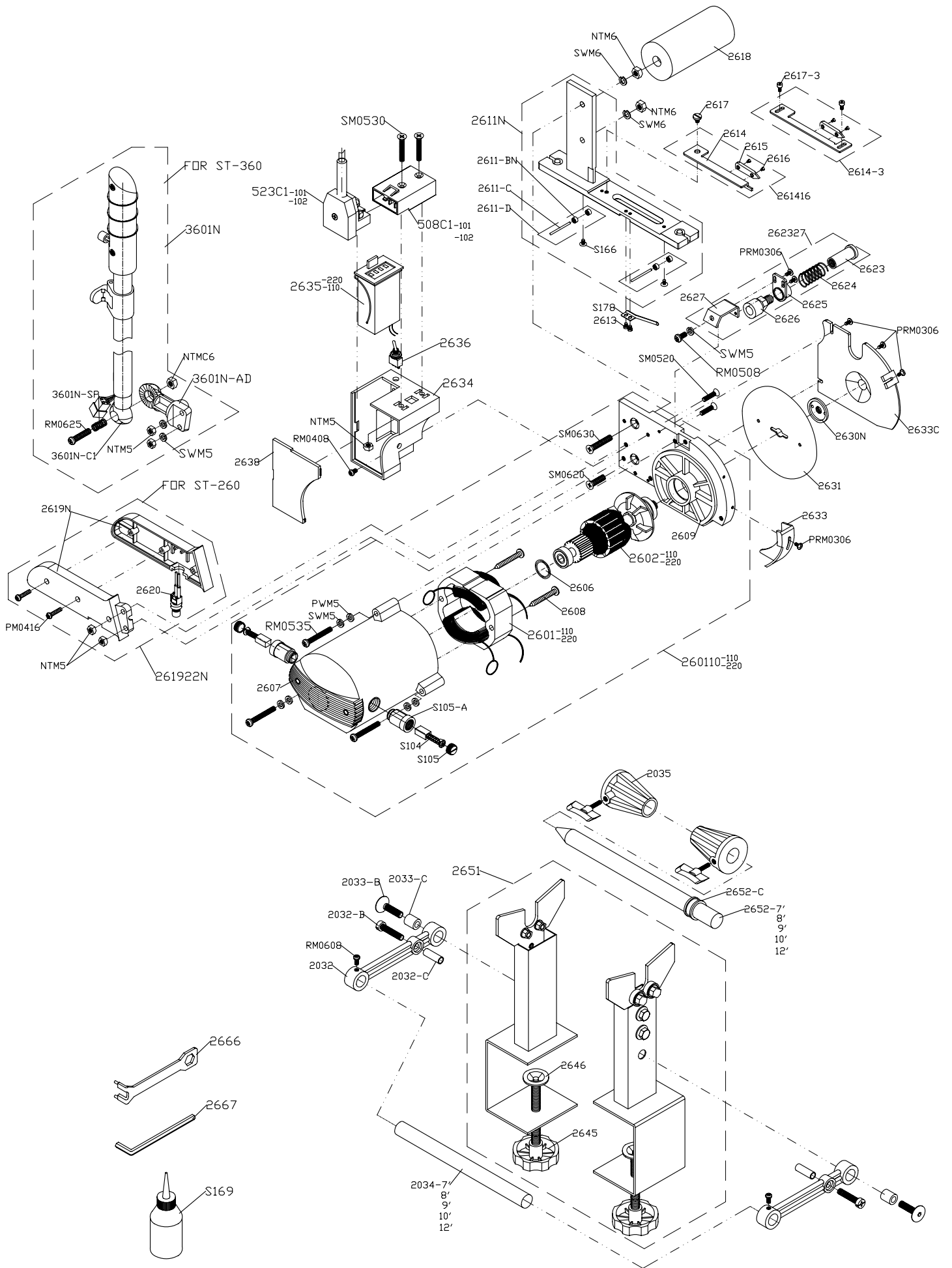



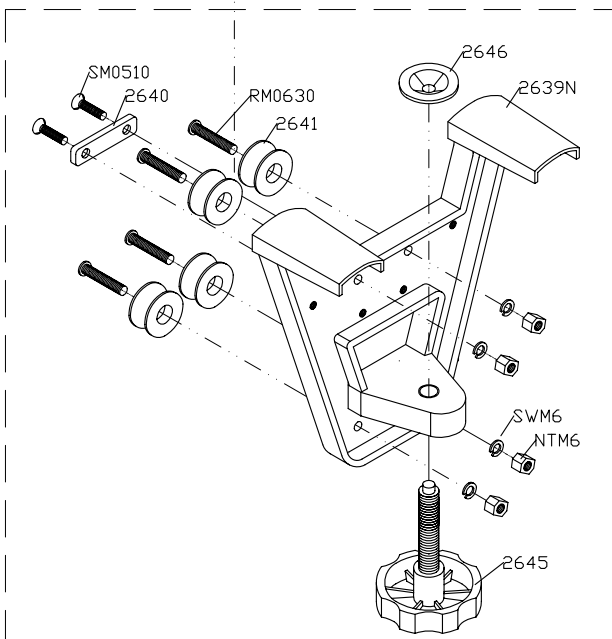
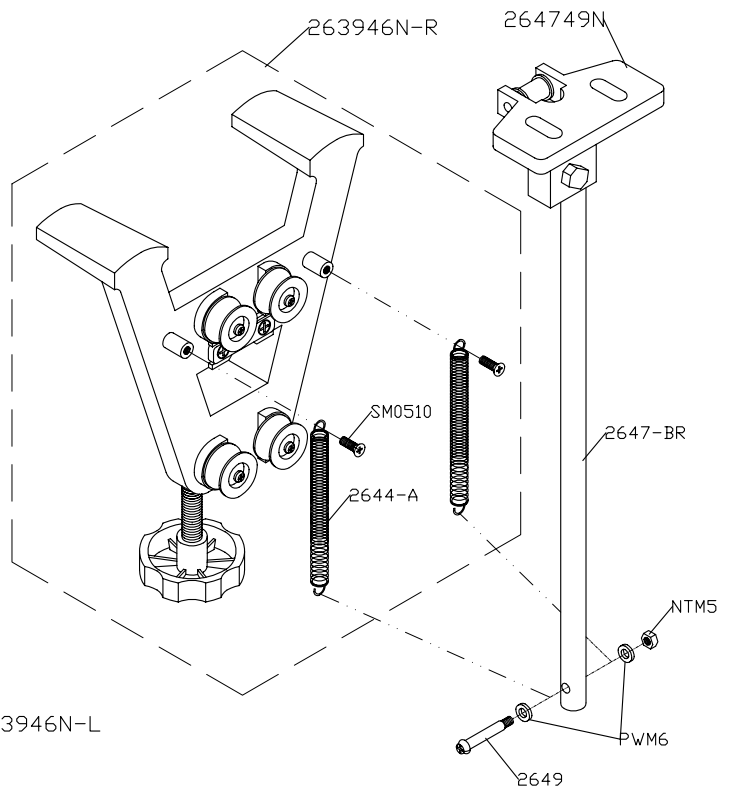
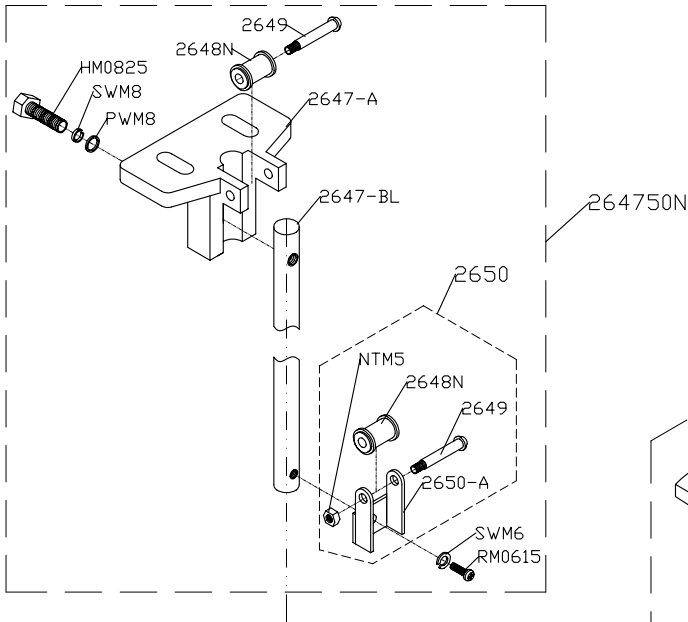
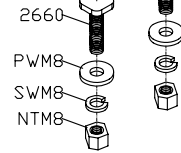
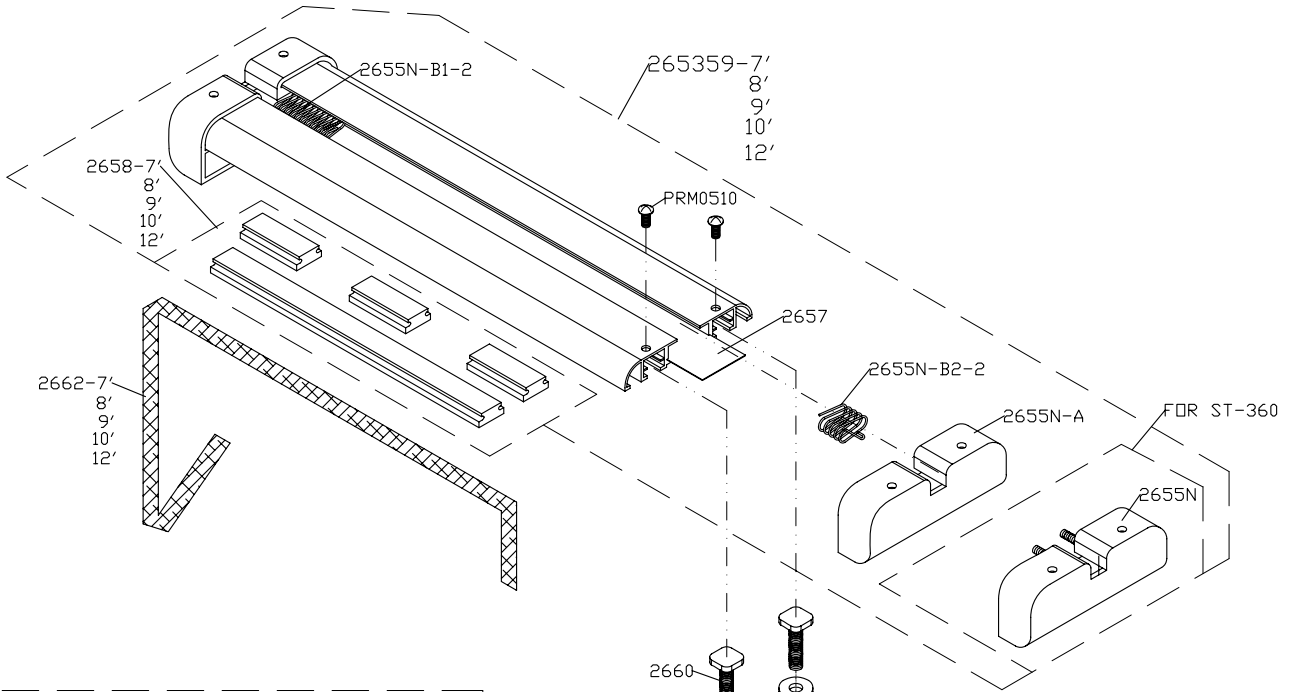

FOR ST-260C & ST-360C & ST-288C MODEL:ER-109

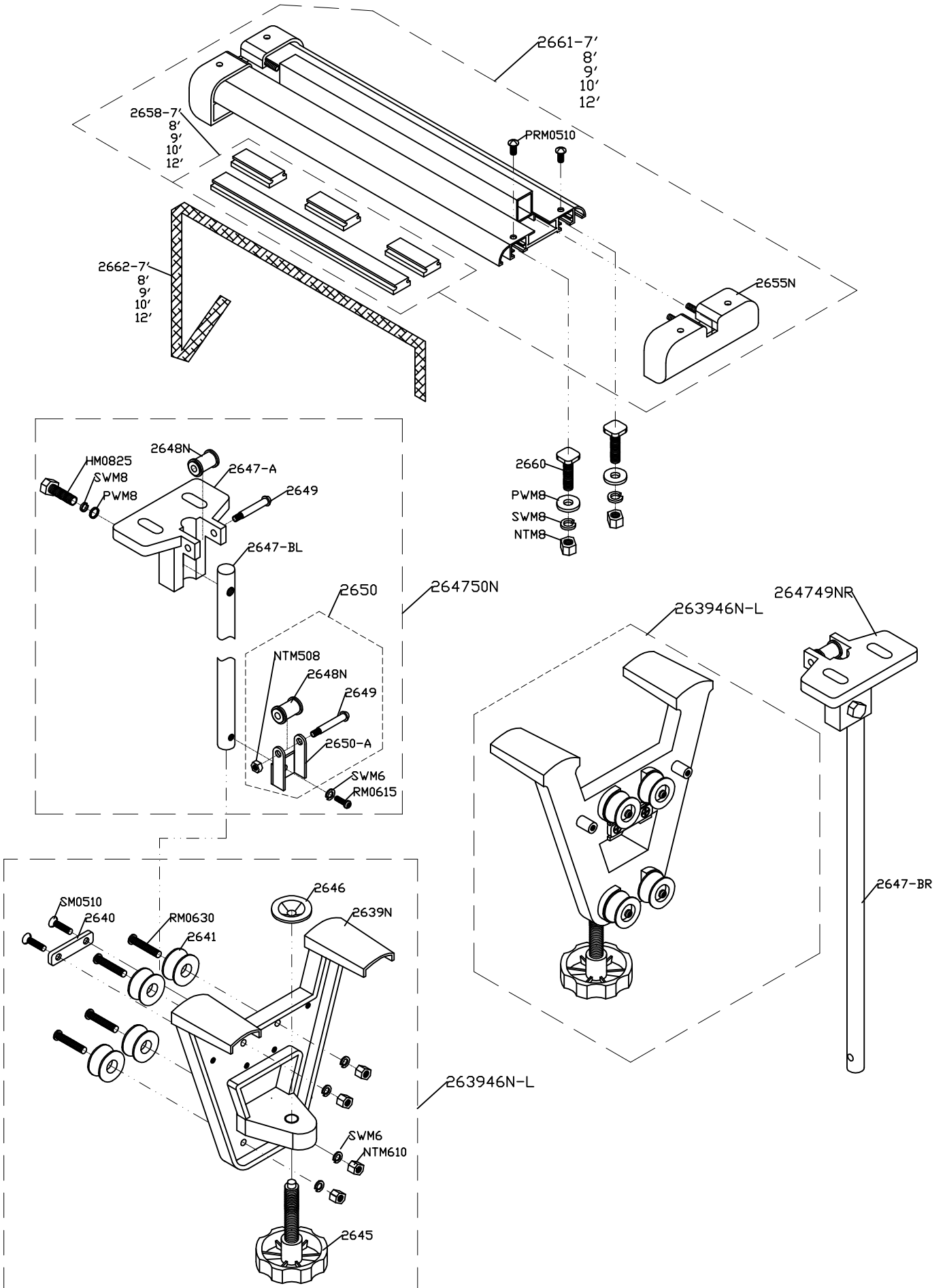

PART NO.	PART NAME	零件名稱	PART NO.	PART NAME	零件名稱
260110-110	110V Motor	110V馬達組	265359-9'	9feet Rail Set	9呎軌道組
260110-220	220V Motor	220V馬達組	-10'	10feet Rail Set	10呎軌道組
260138-110	110V Cutter Head	110V 切刀主機	2655N	Rail Guard	軌道護蓋
260138-220	220V Cutter Head	220V 切刀主機	2655N-B1-2	Long Spring	長防撞彈簧
2601-110	110V Stator	110V 定子	2655N-B2-2	Short Spring	短防撞彈簧
2601-220	220V Stator	220V 定子	2657-7'	7feet Rail Steel Belt	7呎軌道鋼帶
2602-110	110V Armature	110V 轉子	-8'	8feet Rail Steel Belt	8呎軌道鋼帶
2602-220	220V Armature	220V 轉子	-9'	9feet Rail Steel Belt	9呎軌道鋼帶
2606	O Ring	O型環	-10'	10feet Rail Steel Belt	10呎軌道鋼帶
2607	Motor Cover	馬達殼	2658-7'	7feet Rail Rubber belt	7呎軌道膠條
2608	Screw For Stator	定子固定螺絲	-8'	8feet Rail Rubber belt	8呎軌道膠條
2609	Motor Plate	馬達座	-9'	9feet Rail Rubber belt	9呎軌道膠條
2611N	Standard	L型基座	-10'	10feet Rail Rubber belt	10呎軌道膠條
2611-BN	Roller	滑輪	2660	Screw for Rail	軌道固定螺絲
2611-C	Roller Shaft	滑輪軸	2662-8'	8feet Lifter Belt	8呎升降帶
2613	Screw For Pressure Spring	底刀彈片固定螺絲	-10'	10feet Lifter Belt	10呎升降帶
261416	4th Lower Blade	4代底刀組	2666	Wrench	鎖刀扳手
2614	4th Lower Blade Arm	4代底刀架	2667	2.5mm Spanner	2.5mm 內六角扳手
2614-3	3rd Lower Blade	3代底刀組	S104	Carbon Brush	碳刷
2615	Lower Blade	底刀片	S105	Cap for Carbon Brush	碳刷蓋
2616	Screw for Lower Blade	底刀片固定螺絲	S105-A	Seat for Carbon Brush	碳刷座
2617	Screw for 4th Lower Blade	4代底刀組固定螺絲	S169	Oilier	油壺
2617-3	Screw for 3rd Lower Blade	3代底刀組固定螺絲	S178	Pressure Spring for Lower Blade	底刀彈簧
2618	Balance Iron	平衡塊	2032	Rocker	搖臂
261922N	Drive Handle Set	新短手把組	2032-B	Screw for Rocker	搖臂螺絲
2619N	Handle Cover	新短手把蓋	2032-C	Screw Cap	搖臂螺絲套
2620	Switch	手把開關	2033-B	Rocker stop screw	搖桿臂固定螺絲
262327	Sharpener	磨刀石組	2033-C	Rocker stop screw cover	搖桿臂固定螺絲套管
2623	Grinder Collar	磨石套管	2034-7'	7feet Rocker Bar	7呎搖桿棍
2624	Spring for Collar	磨石套管彈簧	-8'	8feet Rocker Bar	8呎搖桿棍
2625	Collar Holder	磨石套管支架	-9'	9feet Rocker Bar	9呎搖桿棍
2626	Emery Wheel	砂輪組	-10'	10feet Rocker Bar	10呎搖桿棍
2627	Grinder Arm	磨刀石架	2035	Cloth Fixture	布卷固定器
2630N	Lock Nut for Knife	銷刀螺帽	508C1-101	220V Socket	220V單相插座組
2631	Round Knife	圓刀片	-102	110V Socket	110V單相插座組
2633	Knife Guard	前護片	523C1-101	220V Cable Set	220V單相插頭組
2633C	Knife Cover	刀片護蓋	-102	110V Cable Set	110V單相插頭組
2634	Terminal Box	配電盒	HM0825	Screw M8x25 Nut Cap	M8x25六角螺絲
2635-110	110V Counter	110V 計數器	NTM508	NUT M5-0.8 Hex	M5六角螺母
2635-220	220V Counter	220V 計數器	NTM610	NUT M6-1.0 Hex	M6六角螺母
2636	Counter Switch	計數器開關	NTM8	NUT M8-1.25 Hex	M8六角螺母
2638	Cover for Terminal Box	配電盒蓋	PM0416	Screw M4x16	M4x16切尾螺絲
263946N-L	Left Clamp Set	新左腳架組	PRM0306	Screw M3x6 Plate Round Cap	M3x6扁圓頭螺絲
263946N-R	Right Clamp Set	新右腳架組	PRM0510	Screw M5x10 Plate Round Cap	M5x10扁圓頭螺絲
2639N	A Clamp	A型腳架	PWM5	Washer 5.3x10	M5平華司
2640	Lift Belt Catch	升降帶固定片	PWM6	Washer 6.4x11.5	M6平華司
2641	Bar lifter Roller	藍輪	PWM8	Washer 8.4x15.5	M8平華司
2644-A	Spring for Lift	提升輔助彈簧	RM0408	Screw M4x8 Round Cap	M4x8圓頭螺絲
2645	Big Screw	轉螺絲	RM0508	Screw M5x8 Round Cap	M5x8圓頭螺絲
2646	Washer for Big Screw	碗型華司	RM0535	Screw M5x35 Round Cap	M5x35圓頭螺絲
264749N	Right Bar Lifter	新右升降桿組	RM0615	Screw M6x15 Round Cap	M6x15圓頭螺絲
264750N	Left Bar Lifter	新左升降桿組	RM0630	Screw M6x30 Round Cap	M6x30圓頭螺絲
2647-A	Bar Lifter Plate	升降桿座	SM0520	Screw M5x20 Flat Cap	M5x20沉頭螺絲
2647-BL	Left Bar	左升降桿	SM0620	Screw M6x20 Flat Cap	M6x20沉頭螺絲
2647-BR	Right Bar	右升降桿	SM0630	Screw M6x30 Flat Cap	M6x30沉頭螺絲
2648N	Roller for Lift Belt	升降帶滑輪	2661-7'	7feet Cloth Hold Bar	7呎壓布軌道組
2649	Roller Shaft	滑輪軸	-8'	8feet Cloth Hold Bar	8呎壓布軌道組
2650	Roller Set	滑輪組	-9'	9feet Cloth Hold Bar	9呎壓布軌道組
2651	Sustaining Frame Unit	撐布支架	-10'	10feet Cloth Hold Bar	10呎壓布軌道組
2652-7'	7feet Sustaining Bar	7呎撐布棍	360138-110	110V Long handle Cutter Head	110V長把切刀主機
-8'	8feet Sustaining Bar	8呎撐布棍	360138-220	220V Long handle Cutter Head	220V長把切刀主機
-9'	9feet Sustaining Bar	9呎撐布棍	3601N	Long Handle	長手把組
-10'	10feet Sustaining Bar	10呎撐布棍	3601N-SP	Spring	轉軸彈簧
2652-C	Sustaining Bar Ring	撐布棍定位環	3601N-C1	Rear Arm	長後段鉛頭
265359-7'	7feet Rail Set	7呎軌道組	3601N-AD	Front Arm	長把短前臂
-8'	8feet Rail Set	8呎軌道組			



速利機械工業有限公司

**SU LEE MACHINE IND.CO.,LTD.**

地址： 臺灣省臺北市北投區磺港路 190 號

NO.190,HWANG GANG RD.,BEITOU,TAIBEI,TAIWAN.

TEL: (886 2)28914693 28927700

FAX: (886 2)28940855

E-mail: [sulee1@ms11.hinet.net](mailto:sulee1@ms11.hinet.net)

Http: [www.sule.com.tw](http://www.sule.com.tw)